

prime | prime 2

Montageanleitung · Mounting instruction · Instruction de montage · Montageaanzijzing



emco

Bitte lesen Sie sich diese Montageanleitung vor dem Einbau vollständig durch. Bewahren Sie diese Montageanleitung immer griffbereit und sicher auf. Das Produkt darf nur in trockene Räume oder in Badezimmerbereiche, die gegen Spritzwasser geschützt sind, eingebaut werden. Der Einbau in Feuchträume wie z. B. Saunen, Schwimmbäder und im Duschbereich ist nicht zulässig. Sorgen Sie immer für ausreichend belüftete Räume, um Schimmelbildung zu vermeiden. Das Produkt darf nur von ausgebildeten Fachleuten montiert werden. **Die EMCO Bad GmbH übernimmt keine Haftung für Schäden, die durch nicht bestimmungsgemäßen Gebrauch entstehen.**

ACHTUNG: Das beigefügte, universelle Befestigungsmaterial ist nicht für alle Untergründe geeignet. Bitte verwenden Sie nur - für den jeweiligen Untergrund - geeignete Schrauben und Dübel. Bitte prüfen Sie deshalb vor der Verwendung sorgfältig, ob das beigefügte Befestigungsmaterial für den jeweils vorgesehenen Untergrund tauglich ist. Ersetzen Sie jede gebrochene Glasscheibe.

Please read these installation instructions carefully before installing the components. Always have these instructions readily available and store them in a safe place. The product may only be installed in dry rooms or in bathrooms that are protected against splashing water. Installation in damp locations such as saunas, swimming pools and shower areas is not permitted. Always ensure that rooms are adequately ventilated to prevent mold growth. The product may be installed only by trained specialists. **EMCO Bad GmbH assumes no liability for damages that occur through non-compliant installation and use.**

CAUTION: The universal fastening accessories supplied with the product are not suitable for all substrates. Please only use screws and plugs that are suitable for the substrate concerned. Therefore, before using the accessories, please carry out a thorough check to ensure that the fastening accessories supplied with the product are suitable for the intended substrate. Replace any broken glass.

Veillez s'il vous plaît lire ce guide de montage en entier avant d'entamer la construction. Conservez toujours ce guide à portée de main et en lieu sûr. Le produit peut seulement être installé dans une chambre sèche ou dans un environnement de salle de bain protégé des gouttes d'eau. Il n'est pas permis de l'installer dans des endroits humides comme par exemple les saunas, les piscines ou près de la douche. Veillez toujours à ce que les pièces soient suffisamment aérées afin d'éviter la formation de moisissures. Le produit ne peut être installé que par des gens de métier spécialisés. **EMCO Bad GmbH n'accepte aucune responsabilité pour des dommages causés par un usage impropre du matériel.**

ATTENTION: le matériel de fixation universel fourni ne convient pas à tous les supports. Veuillez utiliser uniquement les vis et les chevilles appropriées au support respectif. C'est pourquoi, nous vous prions de vérifier soigneusement avant toute utilisation si le matériel de fixation fourni est compatible avec le support prévu.

Remplacer toute vitre cassée.

Leest u alstublieft deze montagevoorschriften voor het inbouwen volledig door. Bewaart u deze montageaanleiding goed en berg deze op binnen handbereik. Het product mogen alleen in droge ruimten of in badkamer gedeelten, welke tegen spatwater beschermt zijn, ingebouwd worden. Het inbouwen in vochtige ruimtes zoals, sauna's, zwembaden en binnen douchebereik is niet geoorloofd. Zorg er altijd voor dat de kamers voldoende geventileerd zijn om schimmelgroei te voorkomen. Het product moeten door een erkend installateur gemonteerd worden. **De Emco organisatie neemt geen verantwoording voor schade welke het gevolg is van ondeskundige montage.**

OPGELET! Het bijgeleverde, universele bevestigingsmateriaal is niet geschikt voor alle ondergronden. Gebruik alleen schroeven en pluggen die geschikt zijn voor de betreffende ondergrond. Controleer daarom a.u.b. vóór gebruik zorgvuldig of het bijgeleverde bevestigingsmateriaal geschikt is voor de bestaande ondergrond.

Vervang alle gebroken glas.

04	elektroanschluss electrical connection · raccordement électrique · elektrische aansluiting
	lieferumfang scope of delivery · quantité livrée · leveromvang
06	- ohne Lichtpaket , without light package, sans option lumineux, zonder lichtpakket
07	- mit Lichtpaket , with light package, avec option lumineux, met lichtpakket
08	montage aufbauversion installing mounted version · montage version montable · montage opbouwuitvoering
12	montage einlegeböden mounting the shelves · montage fond encastré · montage glazen schapjes
	bedienung lichtpaket operation light package · commande des option lumineux · instellen van de lichtpakket
13	einstellungen scharniere adjusting hinges · réglage des charnières · instellen van de scharnieren
15	zusammenbau einbaurahmen assembly installation frame · assemblage châssis de construction · samenstellen inbouwraam
17	montage - einbaurahmen in vorwandsysteme installation frame in wall system · montage châssis à monter sur la paroi montage van inbouwraam in voorzetwand systeem
19	montage - einbaurahmen in metall-ständerwerk installation frame in metal frame work · montage châssis à monter en cadres de métal montage van inbouwraam in metaalstuc systeem
21	montage - einbaurahmen in mauerwerk installation frame in masonry · montage châssis à encastrier · montage van inbouwraam in metselwerk
	lieferumfang scope of delivery · quantité livrée · leveromvang
24	- ohne Lichtpaket , without light package, sans option lumineux, zonder lichtpakket
25	- mit Lichtpaket , with light package, avec option lumineux, met lichtpakket
26	montage - einbauversion installing build in version · montage version encastrable · montage inbouwversie
27	montage einlegeböden mounting the shelves · montage fond encastré · montage glazen schapjes
28	bedienung lichtpaket operation light package · commande des option lumineux · instellen van de lichtpakket
29	einstellungen scharniere adjusting hinges · réglage des charnières · instellen van de scharnieren
30	pflegeanleitung care instructions · notice d'entretien · onderhoudvoorschrift

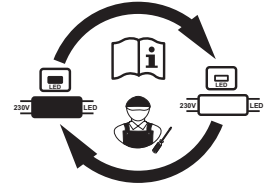

Elektroanschluss Prime-Schränke

01. **Die Elektroinstallation muss von einem Elektro-Fachinstallateur gemäß DIN VDE 0100-701 / IEC 60364-7-701 vorgenommen werden! Nationale sowie örtliche Vorschriften müssen berücksichtigt werden. Die Installation des Produktes muss außerhalb der Schutzzonen 0, 1 und 2 erfolgen.**
02. Das Produkt darf bei einer Beschädigung nicht in Betrieb genommen werden.
03. Das Produkt darf nur vom Hersteller oder einem von ihm beauftragten Servicetechniker repariert werden.
04. Die Anschlussleitung ist in einer geschlossenen Wandleuchten-Anschlussdose entsprechend nach DIN/VDE 0100 Teil 559/2009 – 06 anzuschließen.
05. Das Produkt wird ohne Anschlussklemmen ausgeliefert. Für den Anschluss können Hinweise von Fachpersonen erforderlich sein. Zum Anschluss an das Versorgungsnetz dürfen nur Anschlussklemmen in Übereinstimmung mit EN 60998-2-1 verwendet werden. Es sind drei bzw. vier Klemmen erforderlich (min. 1,5mm², min. 240V, 16A EN 60998-2-1).
06. Eine Verwendung des Produktes ist nur für Innenräume zugelassen. Das Produkt erfüllt die Anforderungen der Schutzart IP20.
07. Die Lichtquellen dieser Leuchte dürfen nur vom Hersteller oder einem von ihm beauftragten Servicetechniker ersetzt werden.
08. Das Netzteil des Produktes darf nur vom Hersteller oder einem von ihm beauftragten Servicetechniker ersetzt werden.
09. Spiegelschrank mit Lichtpaket: Dieses Produkt enthält Lichtquellen der Energieeffizienzklasse F.
10. Spiegelschrank ohne Lichtpaket: Dieses Produkt enthält Lichtquellen der Energieeffizienzklasse E.
11. Nach Entfernen aller Schrauben und Abdeckungen können die Lichtquellen und Betriebsgeräte von einer qualifizierten Person ausgebaut oder ausgetauscht werden.

Electrical connection for Prime cabinets

01. **The electrical installation must be carried out by a qualified electrician in accordance with DIN VDE 0100-701 / IEC 60364-7-701 be taken! National and local regulations must be taken into account. The installation of the product must take place outside of the protection zones 0, 1 and 2.**
02. The product must not be put into operation if it is damaged.
03. The product may only be repaired by the manufacturer or a service technician appointed by him.
04. The connection cable is in a closed wall lamp connection box in accordance with DIN / VDE 0100 Part 559/2009 - 06 to be connected.
05. The product is delivered without connection terminals. Advice from specialists may be required for the connection be. For connection to the supply network, only connection terminals in accordance with EN 60998-2-1 be used. Three or four terminals are required (min. 1.5mm², min. 240V, 16A EN 60998-2-1).
06. Use of the product is only permitted for indoor areas. The product meets the requirements of protection class IP20.
07. The light sources of this lamp may only be replaced by the manufacturer or a service technician commissioned by him.
08. The power supply unit of the product may only be replaced by the manufacturer or a service technician appointed by him.
09. Mirror cabinet with light package: this product contains light sources of energy efficiency class F.
10. Mirror cabinet without light package: this product contains light sources of energy efficiency class E.
11. After removing all screws and covers, the light sources and control gear can be replaced by a qualified person be expanded or replaced.

Raccordement électrique des armoires Prime







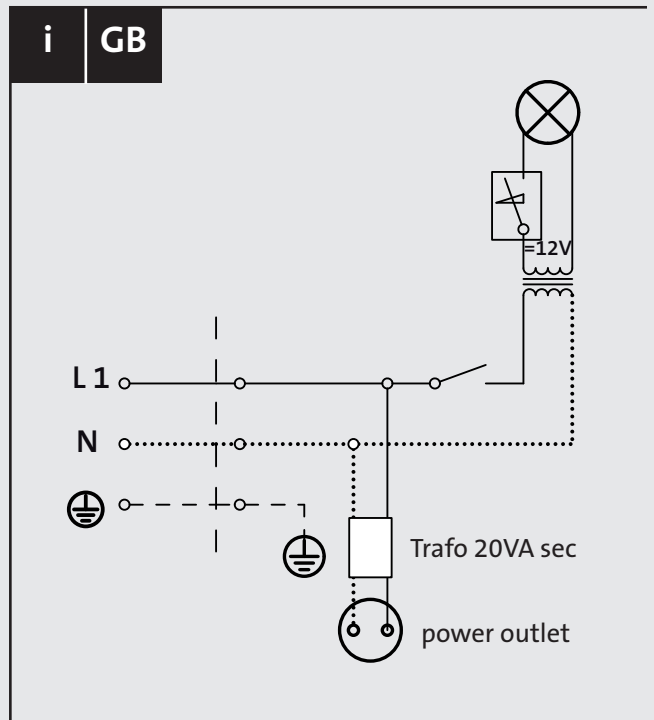
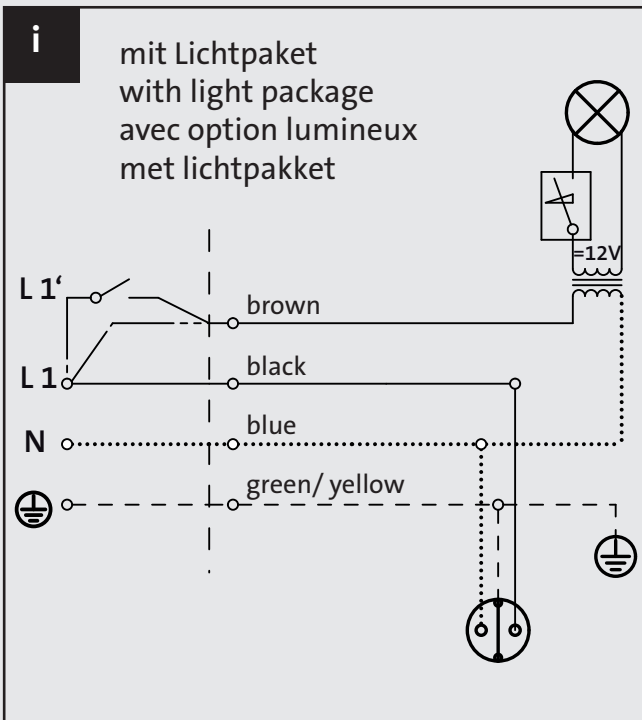
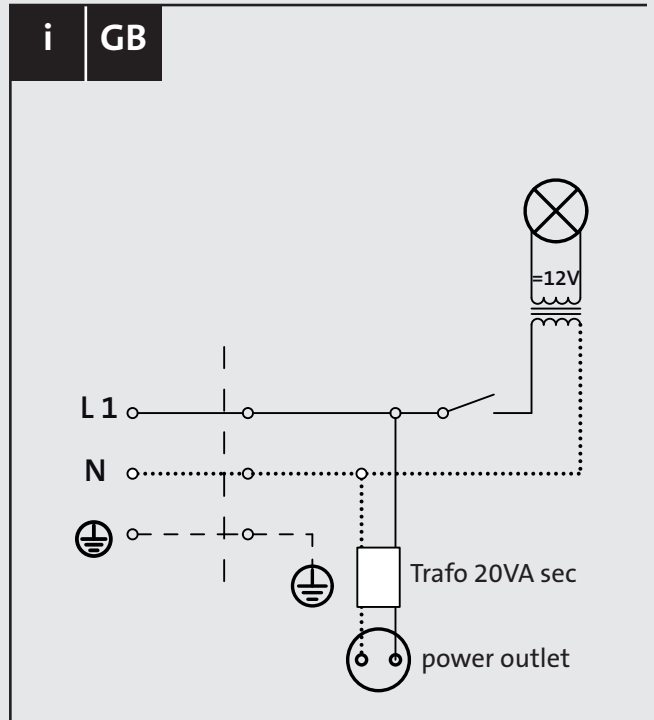
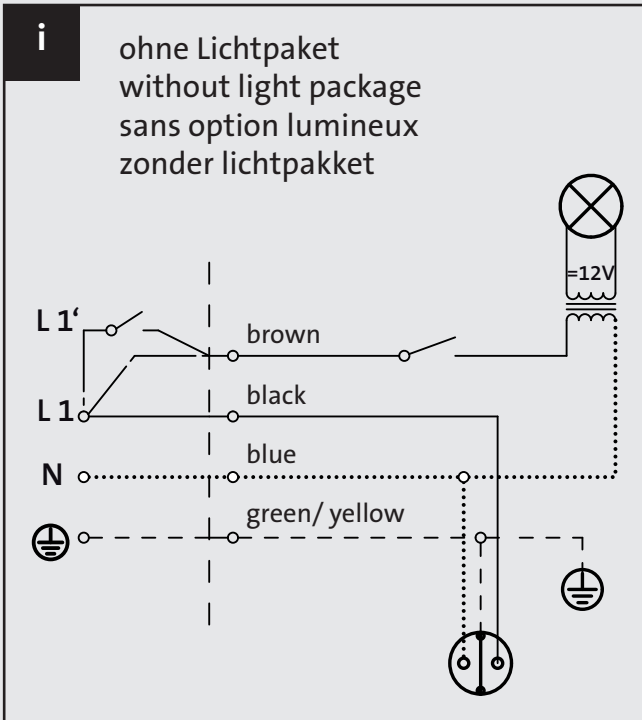



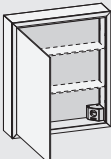

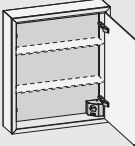

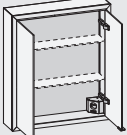



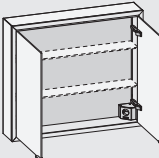

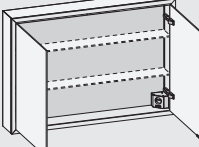
01. **L'installation électrique doit être effectuée par un électricien qualifié conformément à la norme DIN VDE 0100-701 / IEC 60364-7-701 être pris! Les réglementations nationales et locales doivent être prises en compte. L'installation du produit doit avoir lieu en dehors des zones de protection 0, 1 et 2.**
02. Le produit ne doit pas être mis en service s'il est endommagé.
03. Le produit ne peut être réparé que par le fabricant ou un technicien de service désigné par lui.
04. Le câble de raccordement se trouve dans un boîtier de raccordement pour applique murale fermé conformément à la norme DIN / VDE 0100 Pièce 559/2009 - 06 à connecter.
05. Le produit est livré sans bornes de connexion. L'avis de spécialistes peut être nécessaire pour le raccordement être. Pour le raccordement au réseau d'alimentation, uniquement des bornes de raccordement conformes à la norme EN 60998-2-1 être utilisé. Trois ou quatre bornes sont nécessaires (min. 1.5mm², min. 240V, 16A EN 60998-2-1).
06. L'utilisation du produit n'est autorisée que pour les zones intérieures. Le produit répond aux exigences de la classe de protection IP20.
07. Les sources lumineuse de cette lampe ne peut être remplacée que par le fabricant ou un technicien de service mandaté par lui.
08. Le bloc d'alimentation du produit ne peut être remplacé que par le fabricant ou un technicien de service désigné par lui.
09. Armoire avec option lumineux : ce produit contient des sources lumineuse de classe d'efficacité énergétique F.
10. Armoire sans option lumineux : ce produit contient des sources lumineuse de classe d'efficacité énergétique E.
11. Après avoir retiré toutes les vis et couvercles, la sources lumineuse et l'appareillage de commande peuvent être remplacés par une personne qualifiée être agrandi ou remplacé.

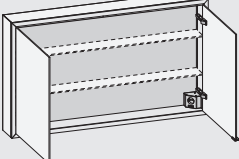
Elektrische aansluiting bij Prime-kasten

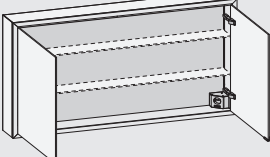

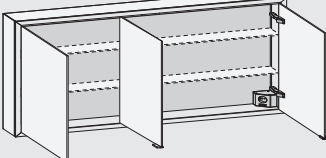







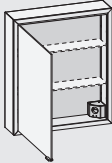

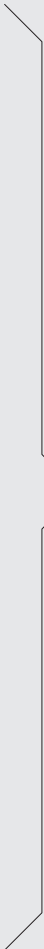

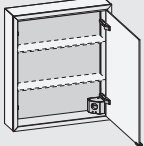

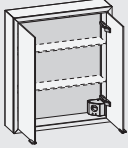

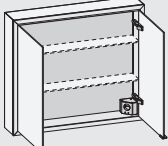

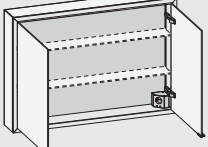

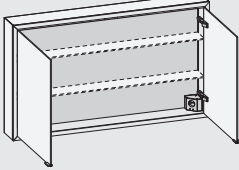

01. **De elektrische installatie moet worden uitgevoerd door een gekwalificeerde elektricien volgens DIN VDE 0100-701 / IEC 60364-7-701 worden genomen! Er moet rekening worden gehouden met nationale en lokale voorschriften. De installatie van het product moet plaatsvinden buiten beschermingszones 0, 1 en 2.**
02. Het product mag niet in gebruik worden genomen als het beschadigd is.
03. Het product mag alleen gerepareerd worden door de fabrikant of een door hem aangewezen servicemonteur.
04. De aansluitkabel zit in een gesloten wandlamp aansluitdoos conform DIN / VDE 0100 Onderdeel 559/2009 - 06 moet worden aangesloten.
05. Het product wordt geleverd zonder aansluitklemmen. Advies van specialisten kan nodig zijn voor de aansluiting worden. Voor aansluiting op het voedingsnet, alleen aansluitklemmen volgens EN 60998-2-1 worden gebruikt. Er zijn drie of vier klemmen nodig (min. 1,5 mm², min. 240 V, 16 A EN 60998-2-1).
06. Gebruik van het product is alleen toegestaan voor binnenruimtes. Het product voldoet aan de eisen van beschermingsklasse IP20.
07. De lichtbronnen van deze lamp mag alleen worden vervangen door de fabrikant of een door hem ingeschakelde servicemonteur.
08. De voeding van het product mag alleen worden vervangen door de fabrikant of een door hem aangewezen servicemonteur.
09. Spiegelkast met lichtpakket: dit product bevat lichtbronnen met energie-efficiëntieklasse F.
10. Spiegelkast zonder lichtpakket: Dit product bevat lichtbronnen met energie-efficiëntieklasse E.
11. Nadat alle schroeven en deksels zijn verwijderd, kunnen de lichtbronnen en de voorschakelapparatuur worden vervangen door een gekwalificeerd persoon worden uitgebreid of vervangen.

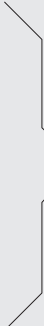

lieferumfang · scope of delivery · quantité livrée · leveromvang
 (ohne Lichtpaket, without light package, sans option lumineux, zonder lichtpakket)

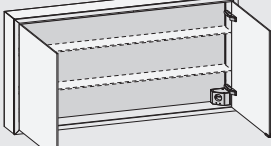
9497 XXX 59 9497 XXX 59		2x 	}		
9497 XXX 21 9497 XXX 21					
9497 XXX 60 9497 XXX 60		2x 			
9497 XXX 22 9497 XXX 22					
9497 XXX 61 9497 XXX 61		2x 			2x 
9497 XXX 23 9497 XXX 23					3x 
9497 XXX 62 9497 XXX 62		2x 			1x 
9497 XXX 24 9497 XXX 24					
9497 XXX 83 9497 XXX 83		2x 			
9497 XXX 45 9497 XXX 45					
9497 XXX 84 9497 XXX 84		2x 			
9497 XXX 46 9497 XXX 46					
9497 XXX 85 9497 XXX 85		2x 	2x 		
9497 XXX 47 9497 XXX 47					
9497 XXX 86 9497 XXX 86		2x 	5x /5x 		
9497 XXX 48 9497 XXX 48		2x 		1x 	

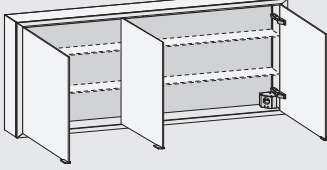
lieferungsumfang · scope of delivery · quantité livrée · leveromvang
 (mit Lichtpaket, with light package, avec option lumineux, met lichtpakket)

9497 XXX 59 9497 XXX 59		2x 		 2x  3x
9497 XXX 21 9497 XXX 21				
9497 XXX 60 9497 XXX 60		2x 		
9497 XXX 22 9497 XXX 22				
9497 XXX 61 9497 XXX 61		2x 		
9497 XXX 23 9497 XXX 23				
9497 XXX 62 9497 XXX 62		2x 		
9497 XXX 24 9497 XXX 24				
9497 XXX 83 9497 XXX 83		2x 	 1x 	
9497 XXX 45 9497 XXX 45				
9497 XXX 84 9497 XXX 84		2x 		2x  5x / 5x  1x  1x 
9497 XXX 46 9497 XXX 46				
9497 XXX 85 9497 XXX 85		2x 		
9497 XXX 47 9497 XXX 47				
9497 XXX 86 9497 XXX 86		2x 		
9497 XXX 48 9497 XXX 48		2x 		

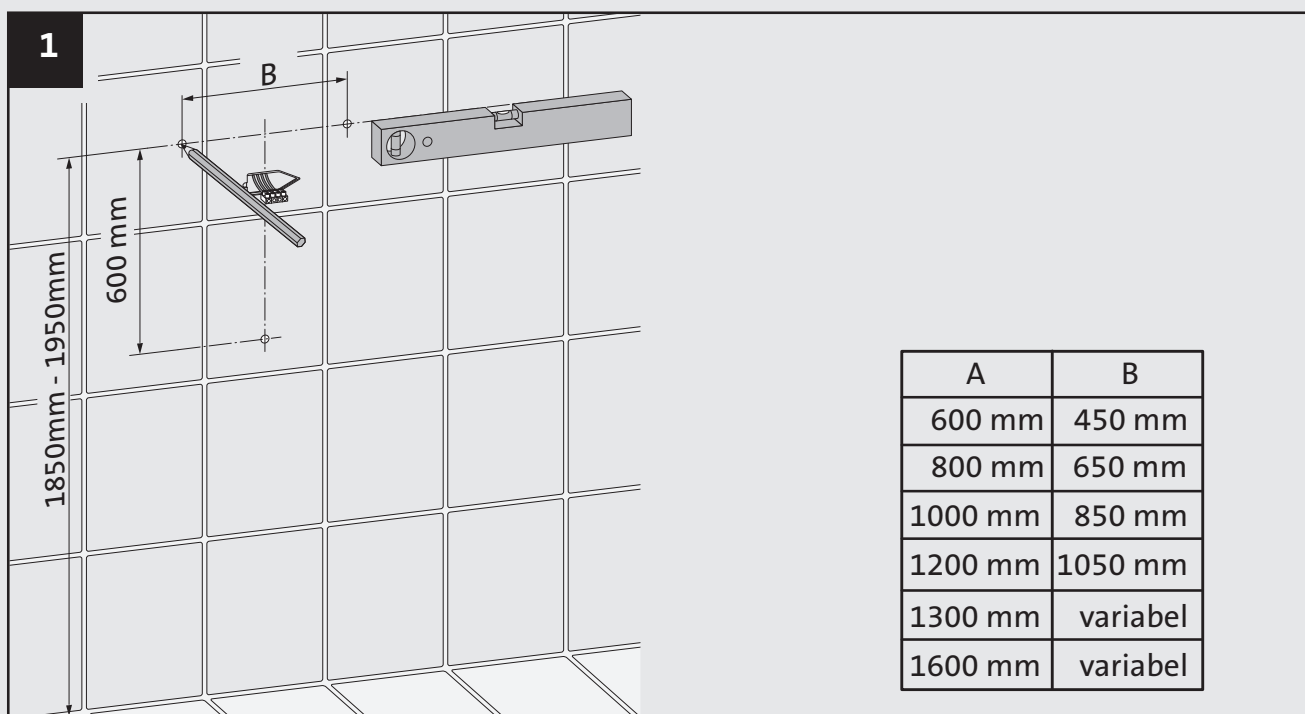
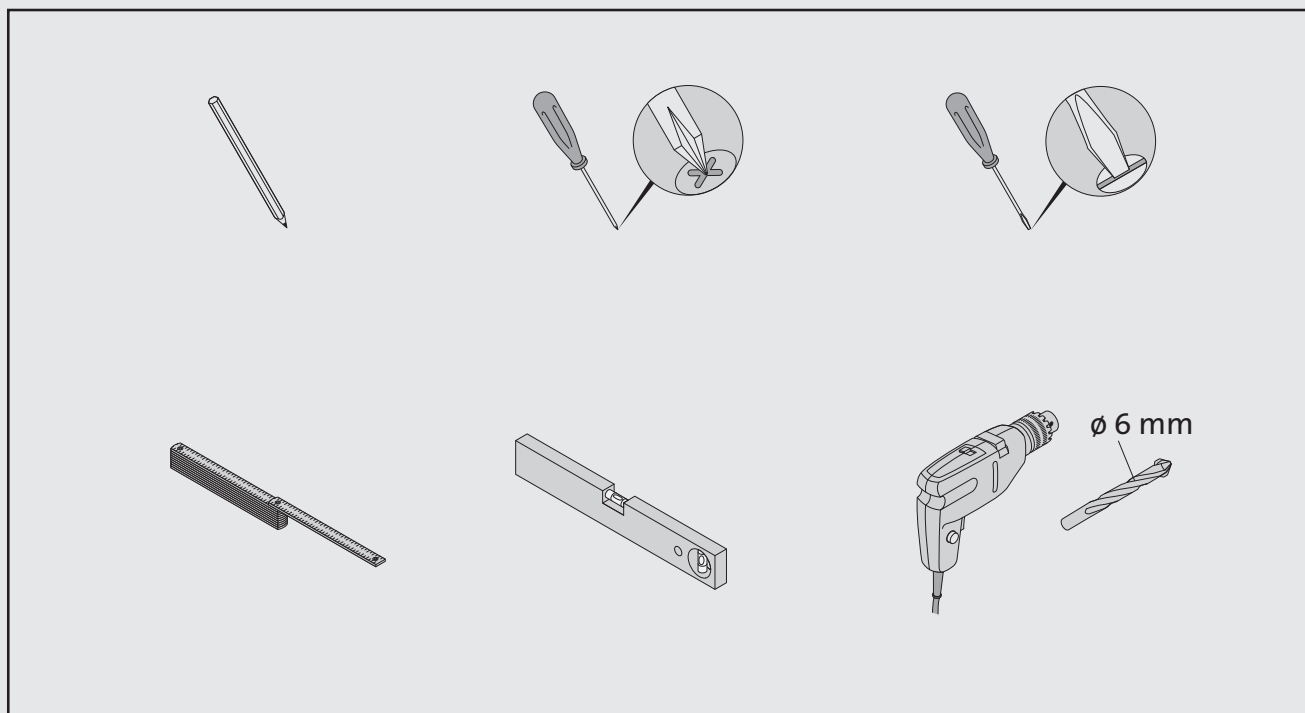

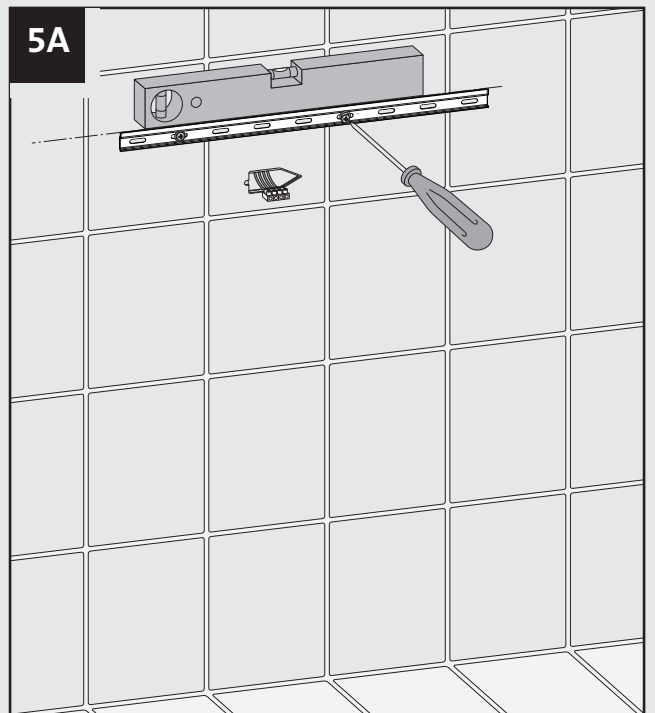
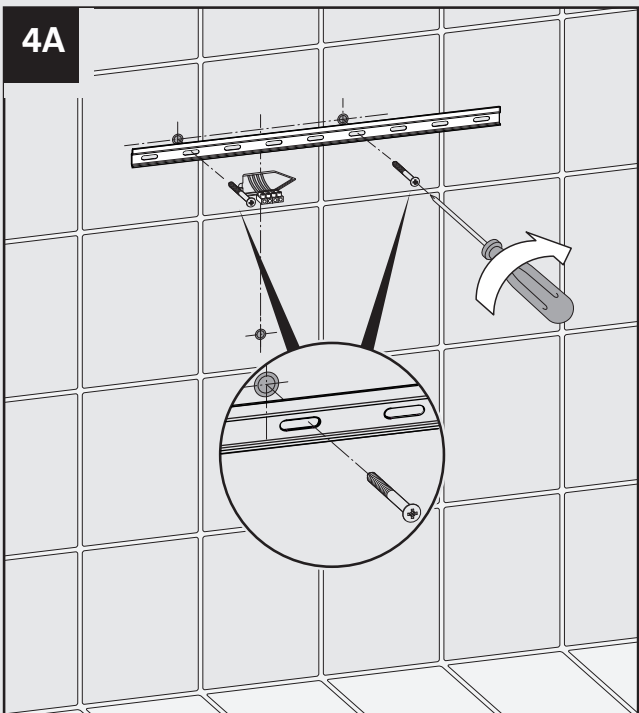
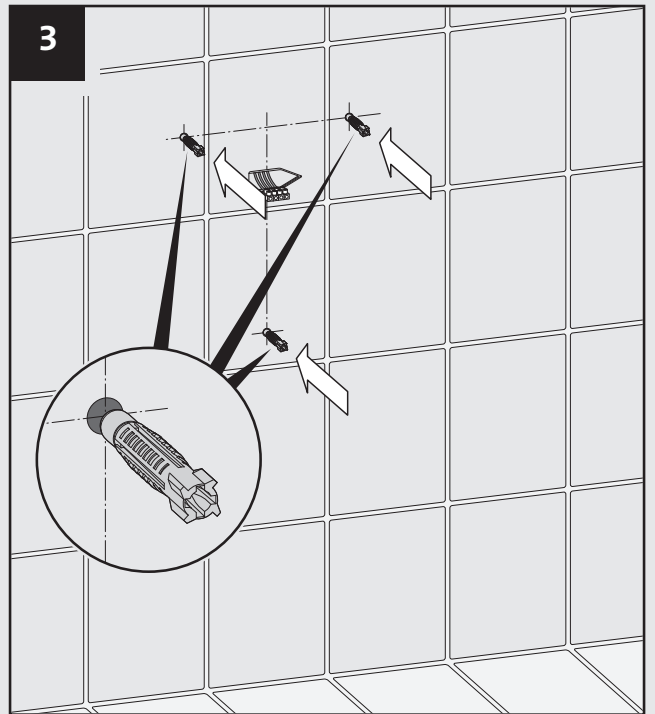
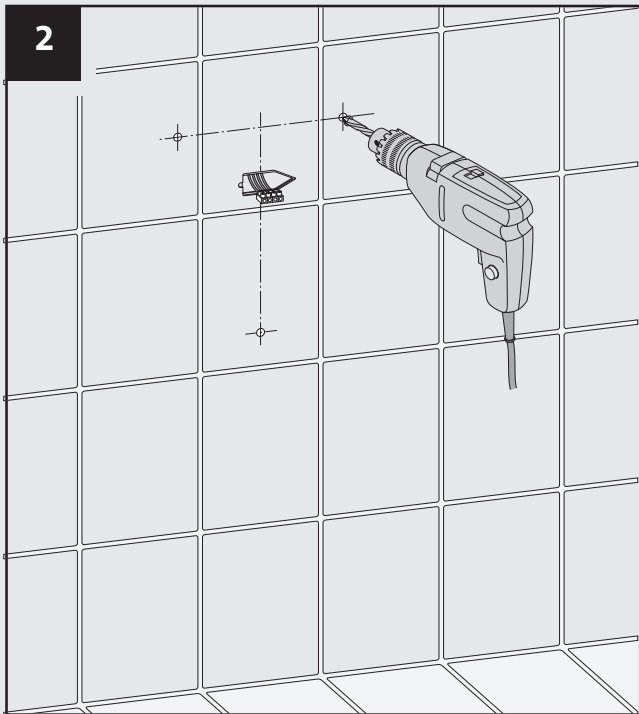

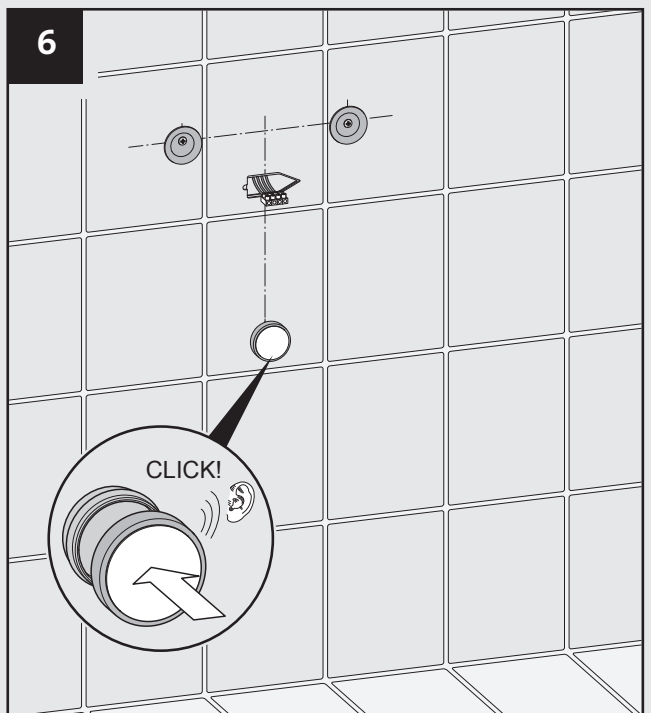
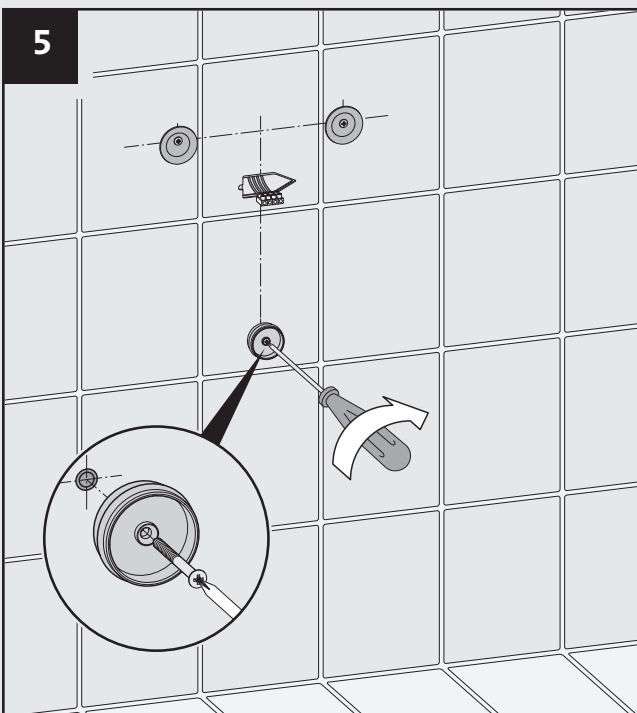
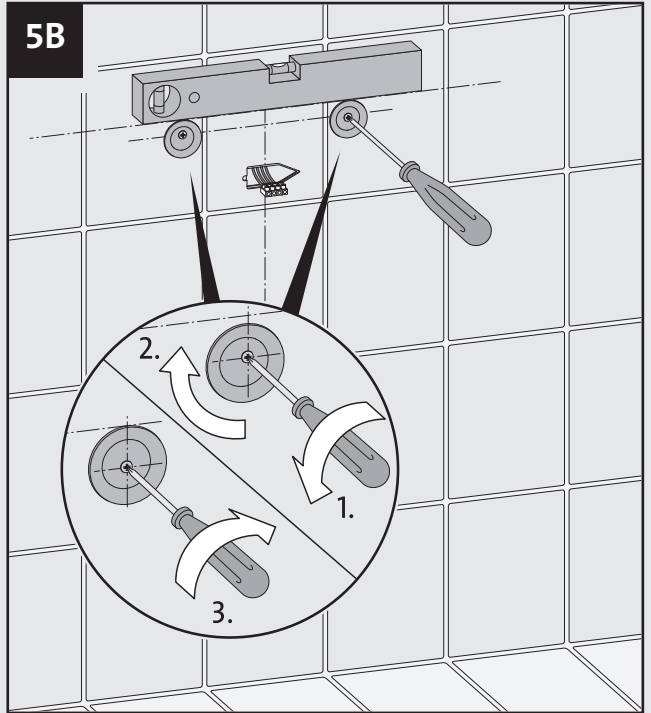
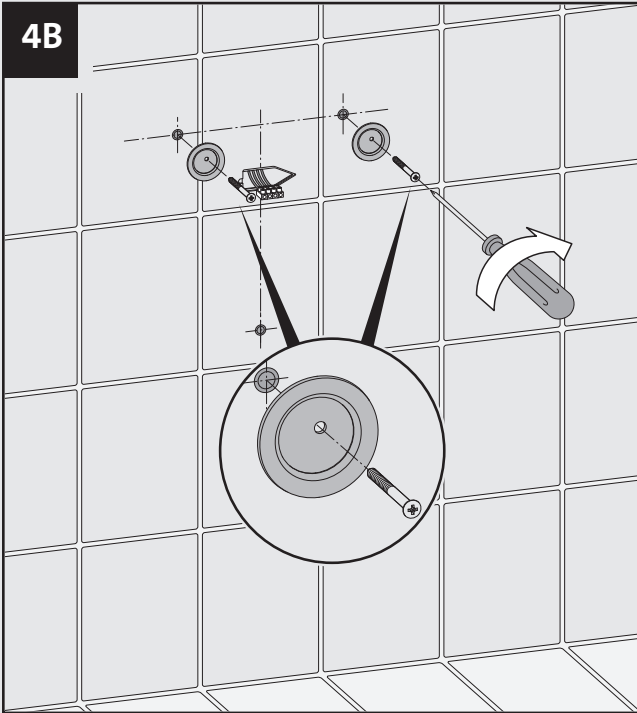

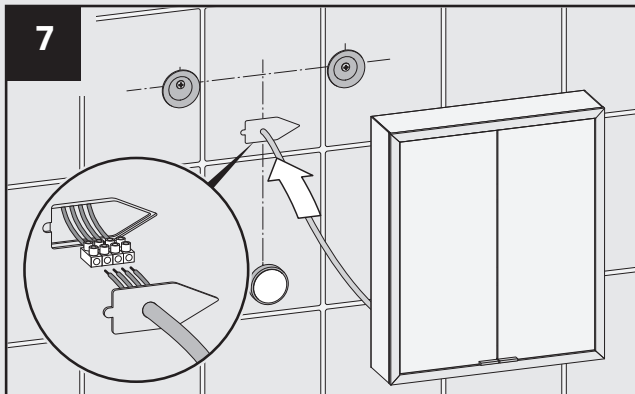

7
Es sind drei bzw. vier Klemmen erforderlich
(min. 1,5mm², min. 240V, 16A, EN 60998-2-1)

Three or four terminals are required
(min. 1,5mm², min. 240V, 16A, EN 60998-2-1)

Trois ou quatre bornes sont nécessaires
(min. 1,5mm², min. 240V, 16A, EN 60998-2-1)

Hier zijn drie of vier klemmen vereist
(min. 1,5mm², min. 240V, 16A, EN 60998-2-1)

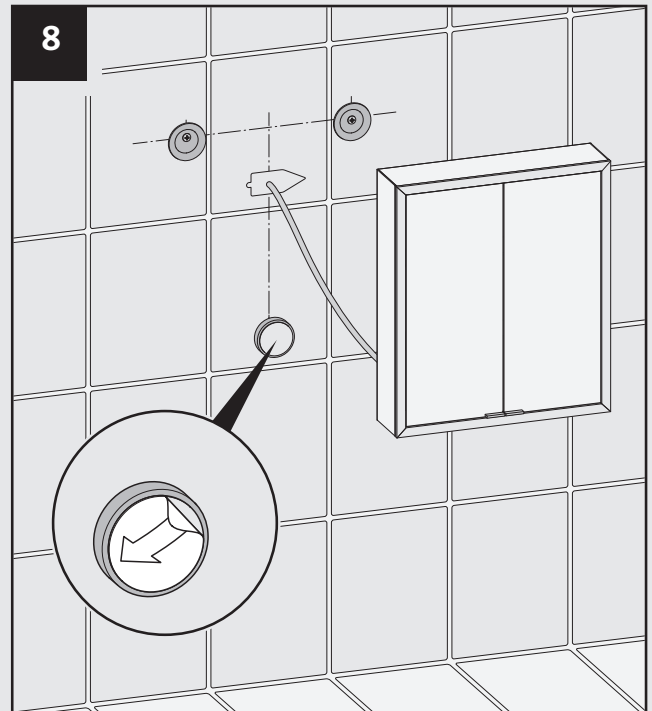

8

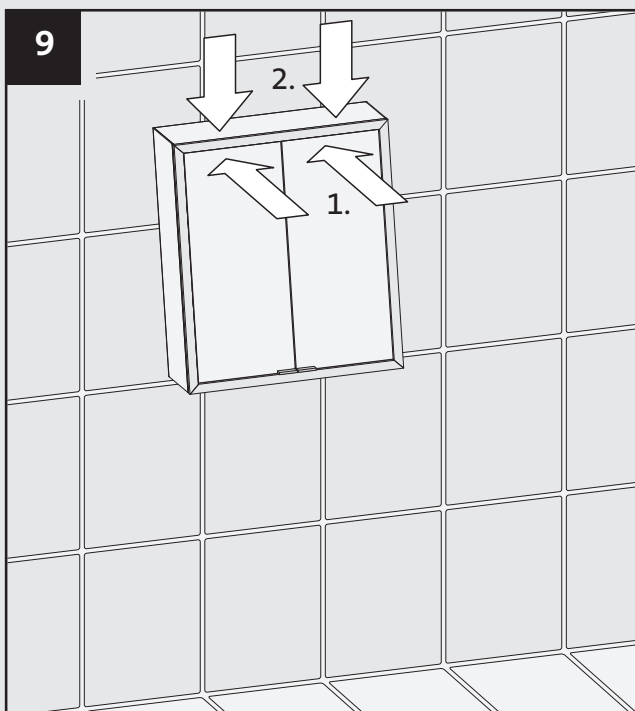

9

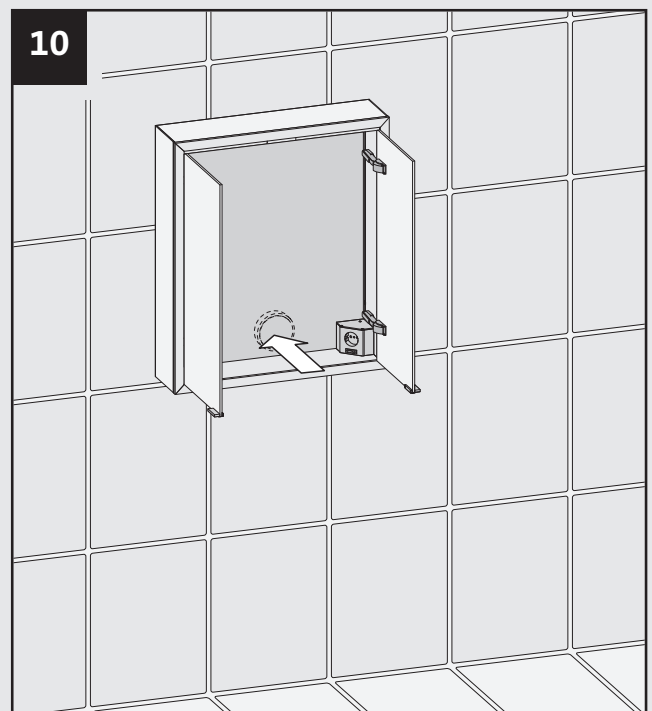

10

montage einlegeböden · mounting the shelves · montage fond encastré · montage glazen schapjes

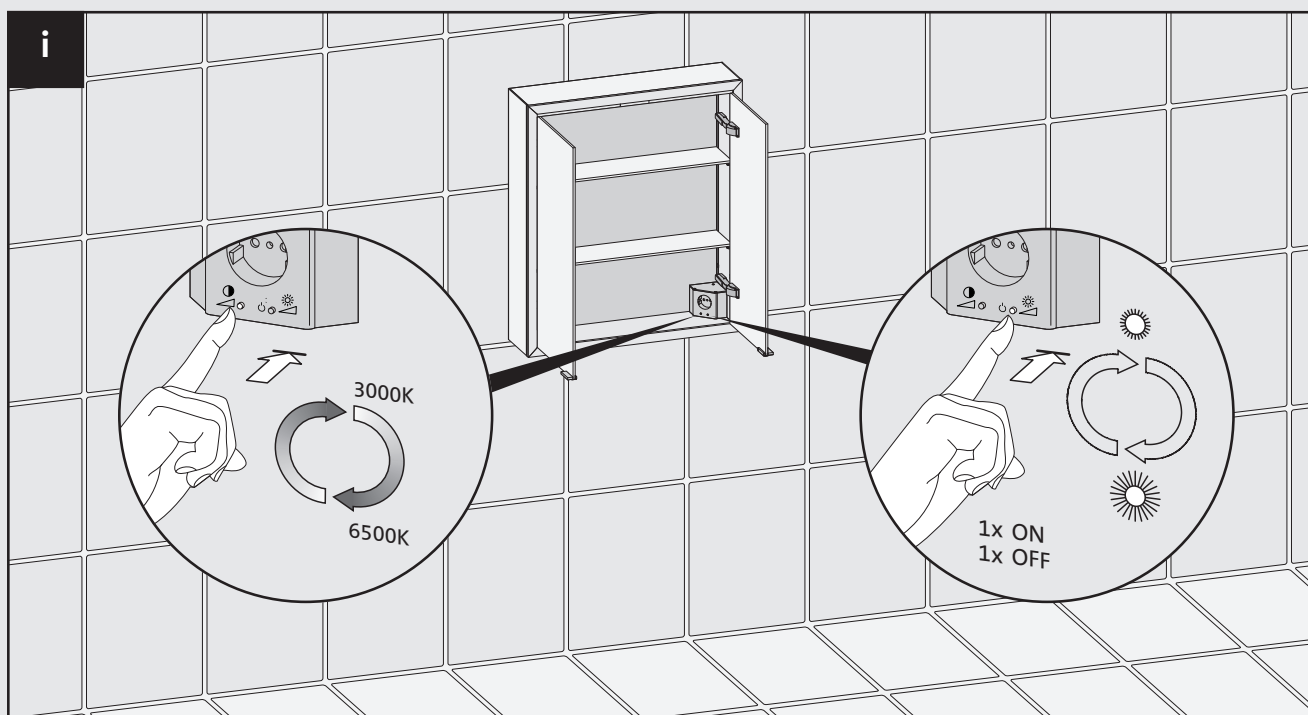
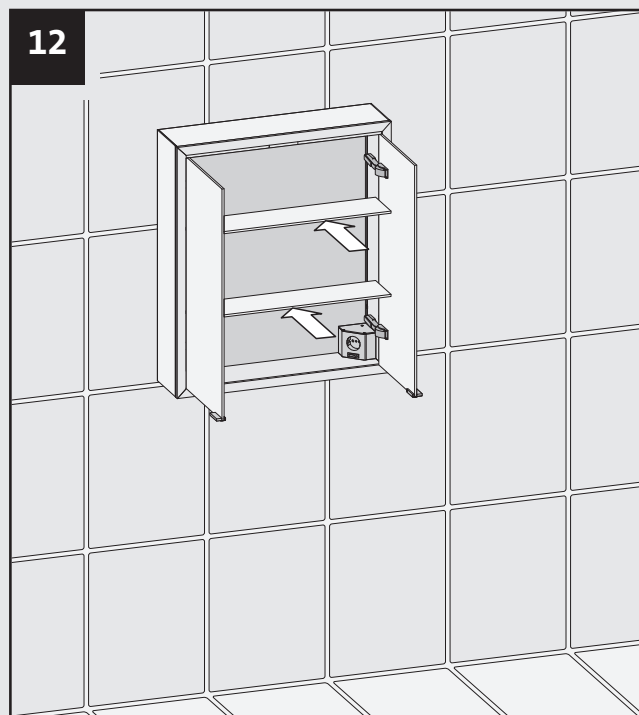
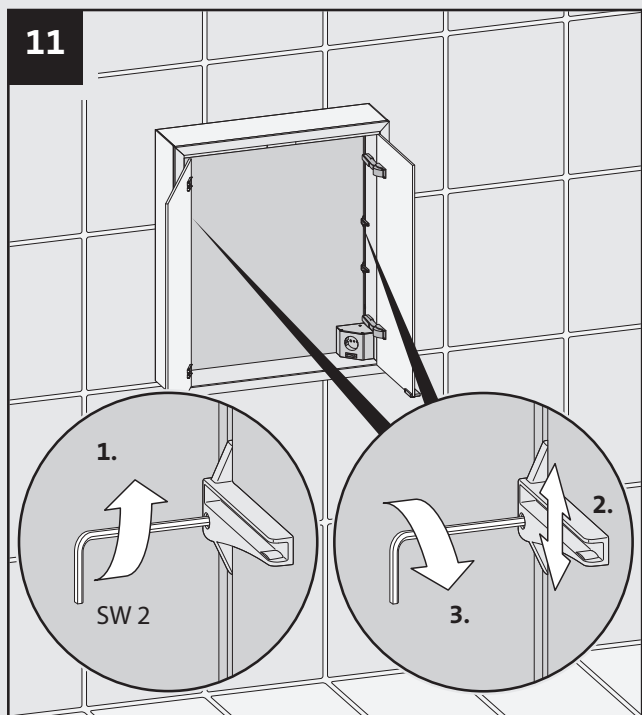

bedienung lichtpaket · operation light package · commande des option lumineux · instellen van de lichtpakket

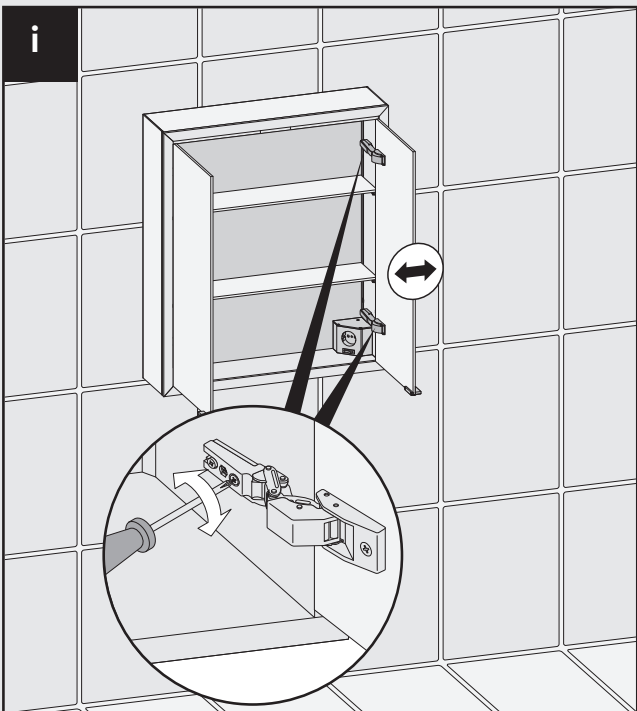
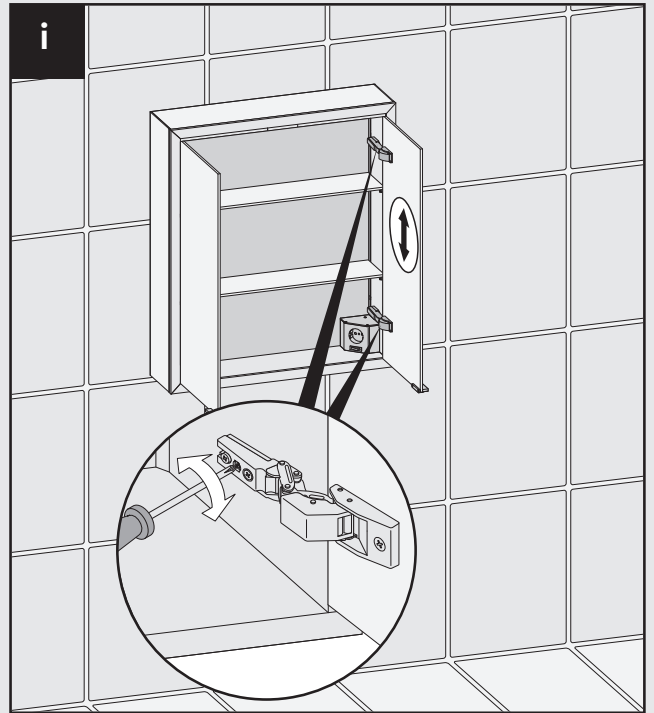
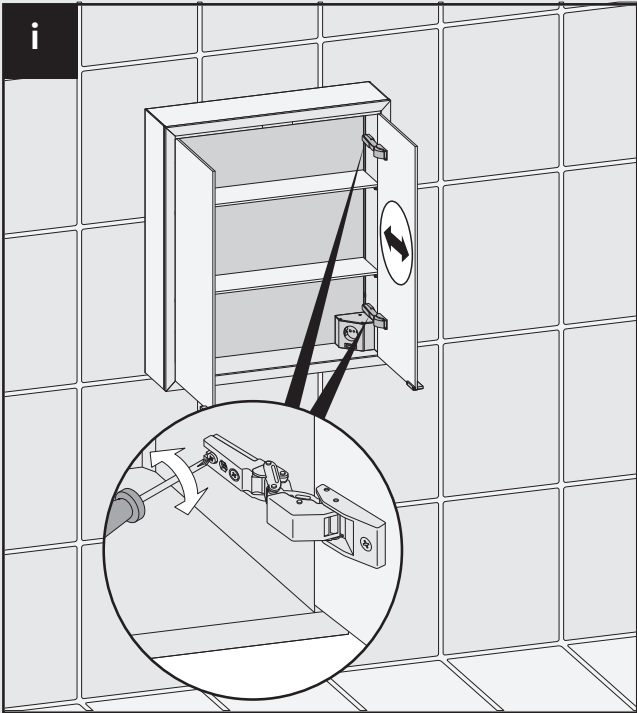

einstellungen scharniere · adjusting hinges · réglage des charnières · instellen van de scharnieren



9497 000 10	2x		4x	
9497 000 20	2x		4x	
			8x	
9497 000 11	2x		4x	
9497 000 19	2x		4x	
			8x	
9497 000 12	2x		4x	
9497 000 18	2x		4x	
			8x	
9497 000 13	2x		4x	
9497 000 17	2x		4x	
			8x	
9497 000 14	2x		4x	
9497 000 16	2x		4x	
9497 000 15	2x		4x	
9497 000 29	2x		8x	



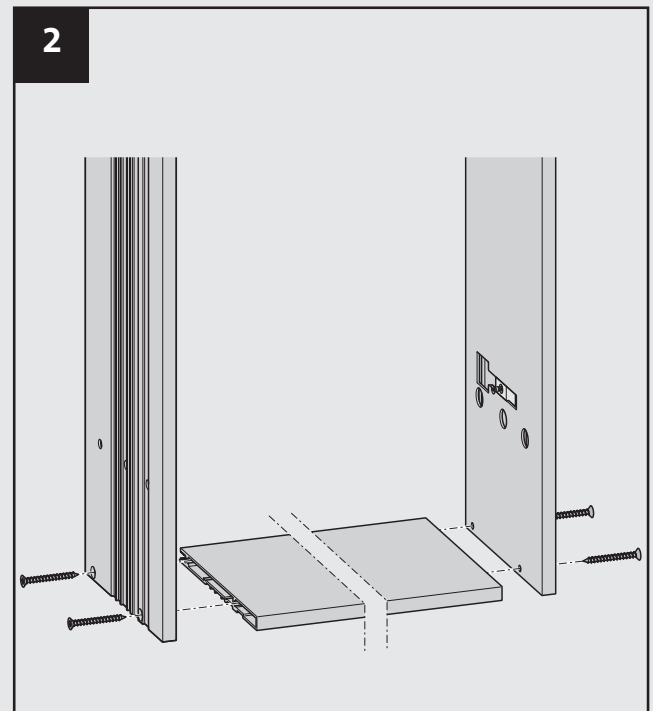
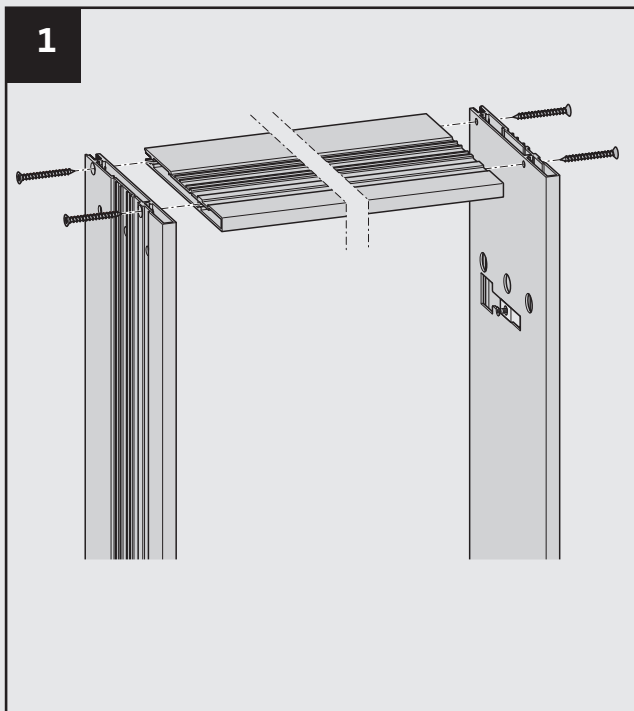

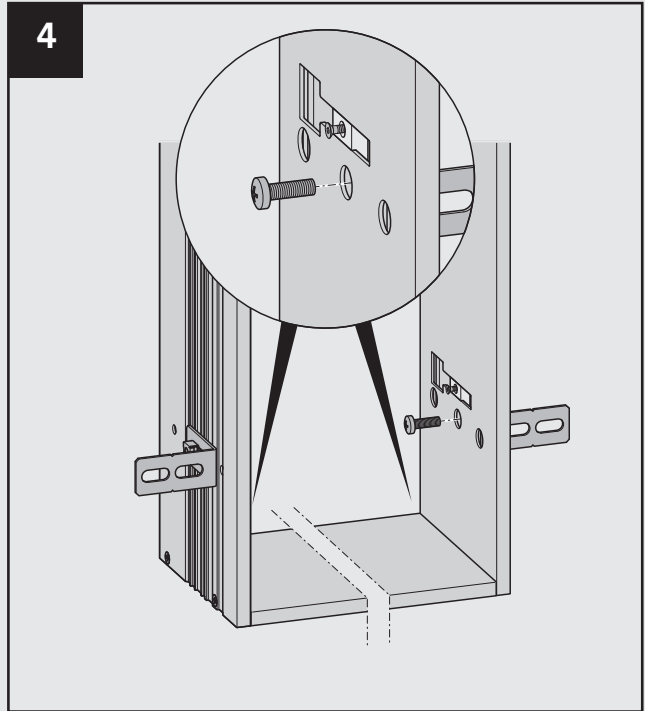
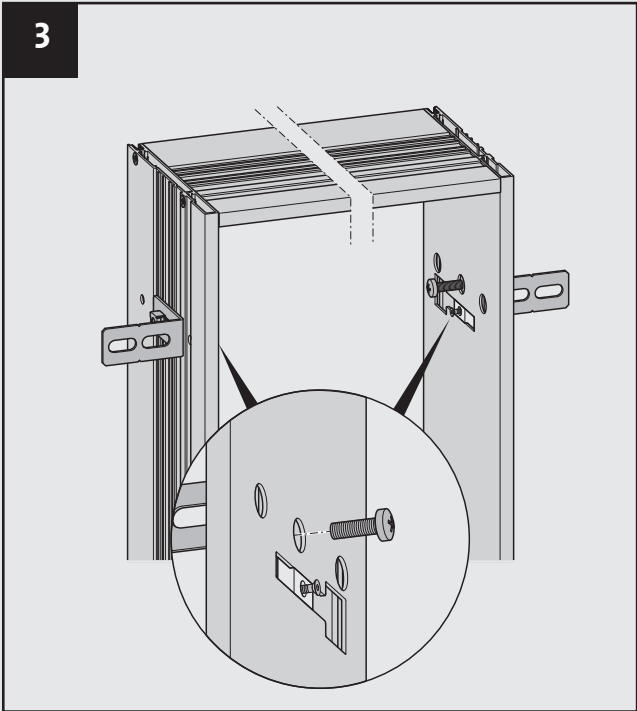
montage einbaurahmen in vorwandssysteme · installation frame in wall system · montage châssis à monter sur la paroi
 montage van inbouwraam in voorzetwand systeem

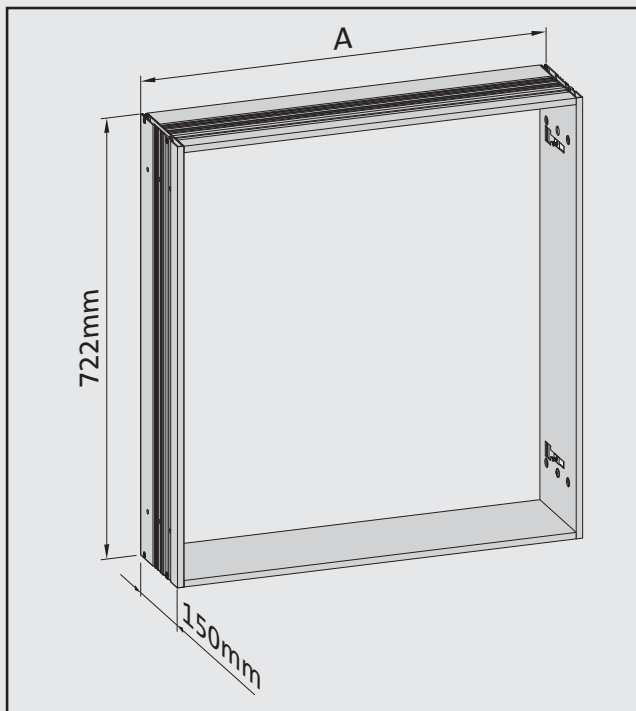

Art.-Nr. Prime	A
9497 000 10	622 mm
9497 000 11	822 mm
9497 000 12	1022 mm
9497 000 13	1222 mm
9497 000 14	1322 mm
9497 000 29	1622 mm

Art.-Nr. Prime 2	A
9497 000 20	599 mm
9497 000 19	799 mm
9497 000 18	999 mm
9497 000 17	1199 mm
9497 000 16	1299 mm
9497 000 15	1599 mm

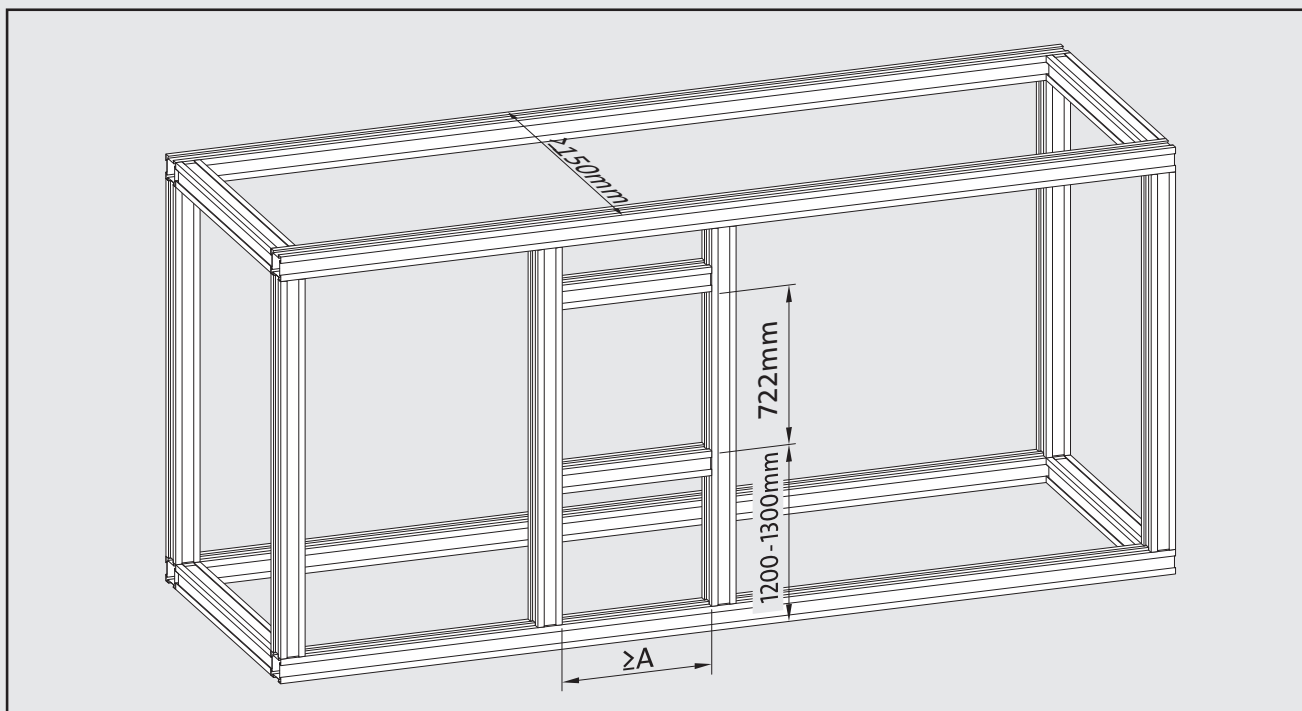

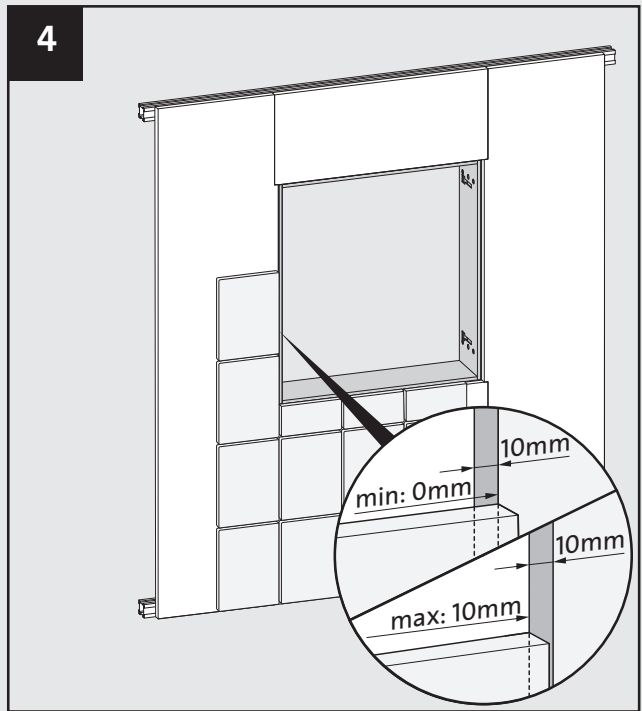
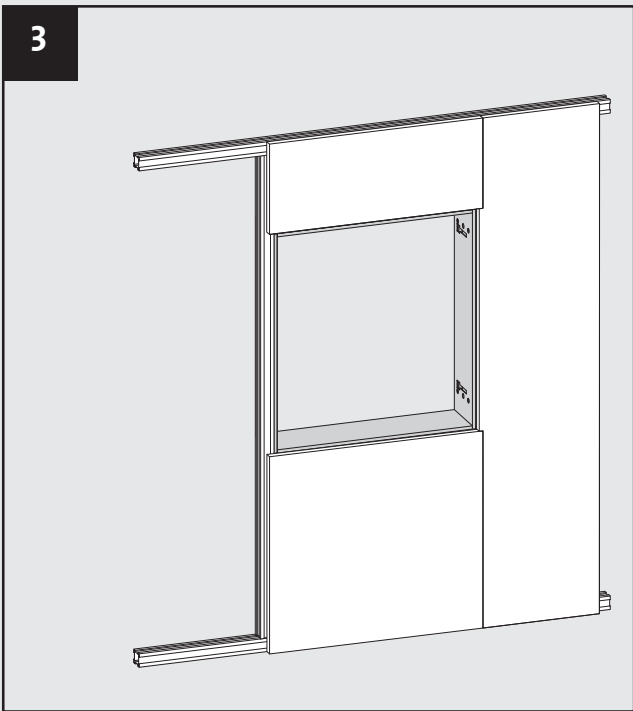
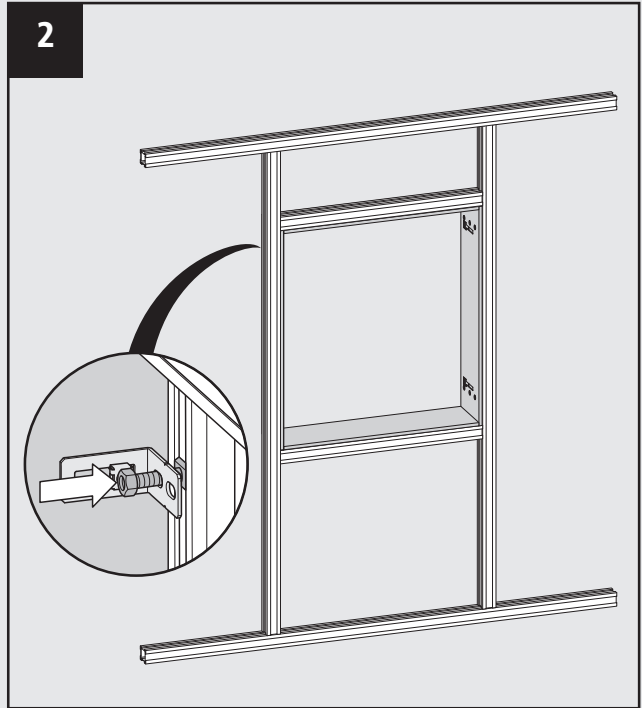
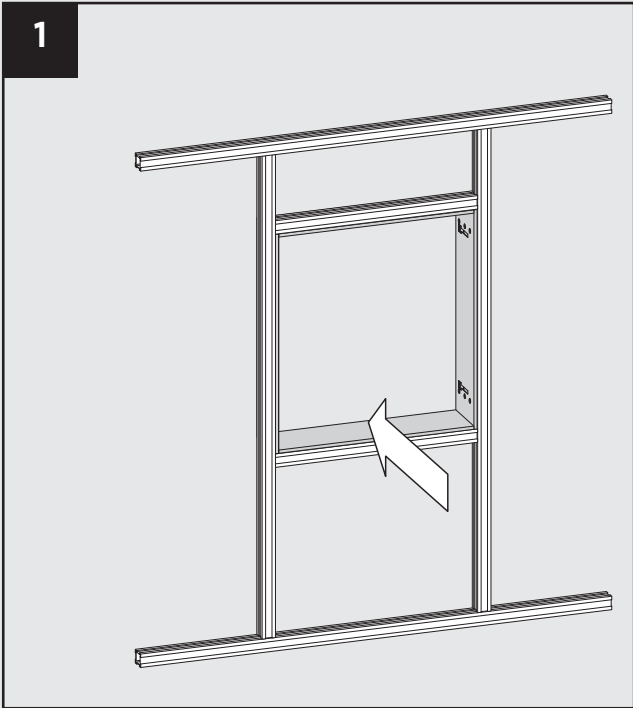

montage - einbaurahmen in metall-ständerwerk · installation frame in metal frame work
 montage châssis à monter en cadres de métal · montage van inbouwraam in metaalstuc systeem

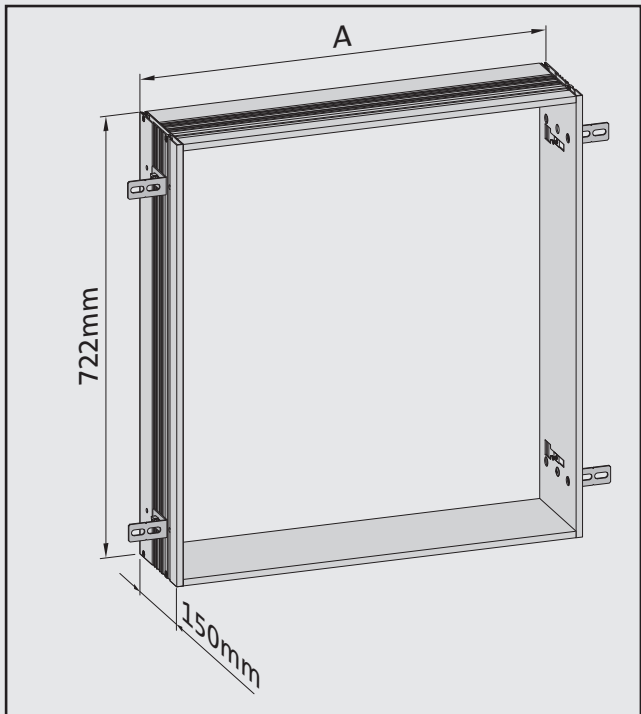

Art.-Nr. Prime	A
9497 000 10	622 mm
9497 000 11	822 mm
9497 000 12	1022 mm
9497 000 13	1222 mm
9497 000 14	1322 mm
9497 000 29	1622 mm

Art.-Nr. Prime 2	A
9497 000 20	599 mm
9497 000 19	799 mm
9497 000 18	999 mm
9497 000 17	1199 mm
9497 000 16	1299 mm
9497 000 15	1599 mm

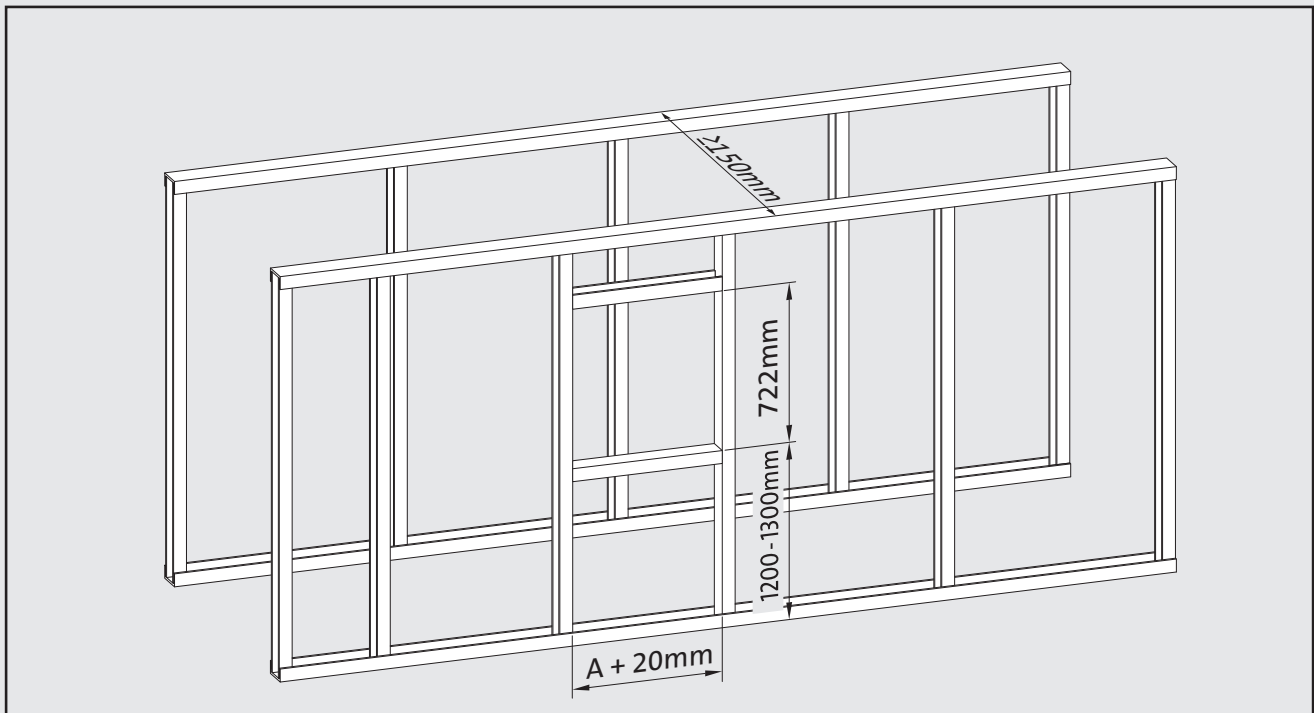

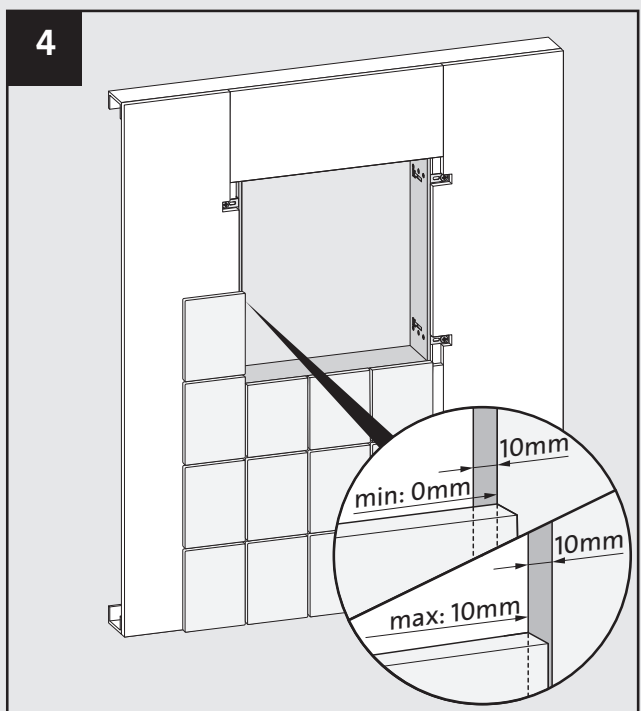
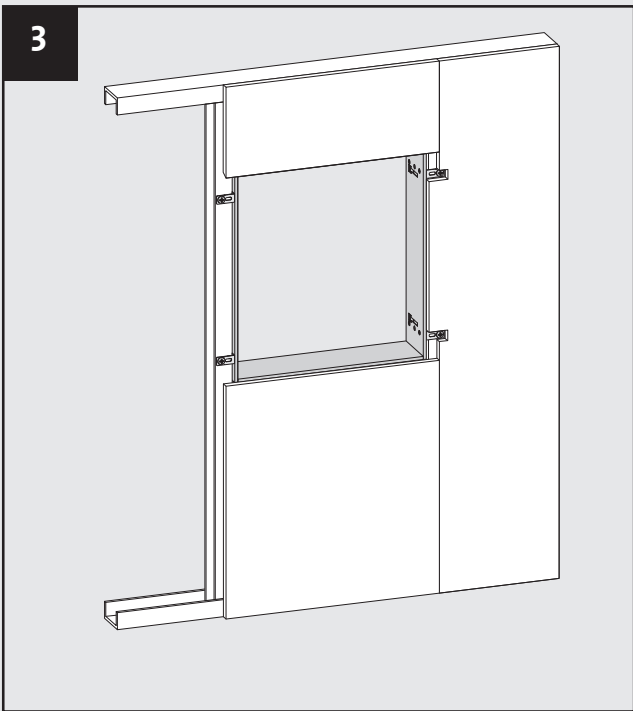
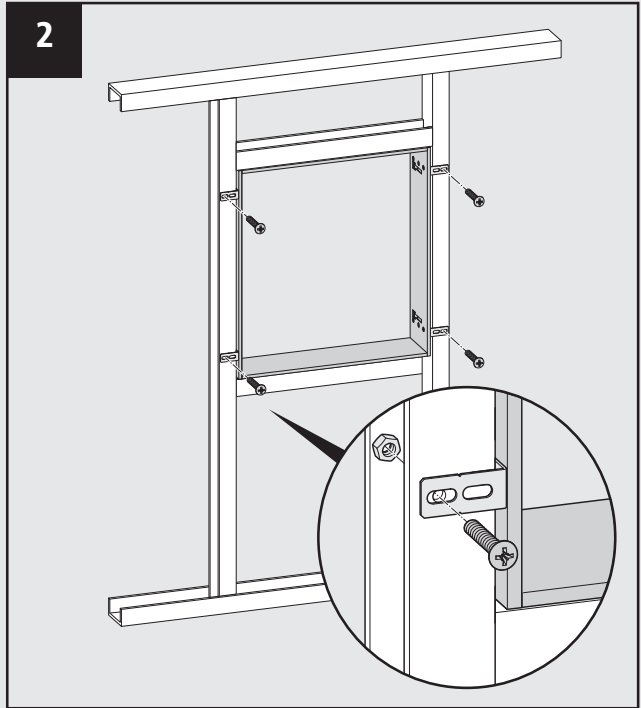
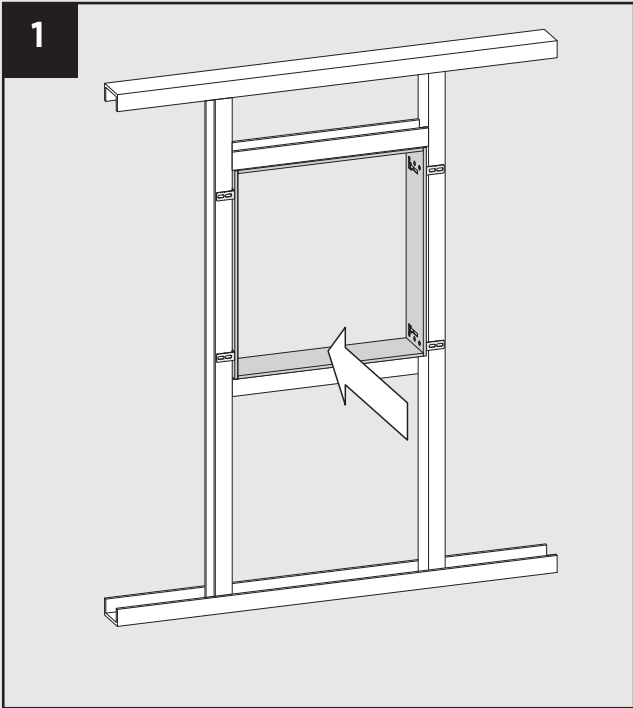

montage einbaurahmen in mauerwerk · installation frame in masonry · montage châssis à encastrer
montage van inbouw-raam in metselwerk

Art.-Nr. Prime	A
9497 000 10	622 mm
9497 000 11	822 mm
9497 000 12	1022 mm
9497 000 13	1222 mm
9497 000 14	1322 mm
9497 000 29	1622 mm

Art.-Nr. Prime 2	A
9497 000 20	599 mm
9497 000 19	799 mm
9497 000 18	999 mm
9497 000 17	1199 mm
9497 000 16	1299 mm
9497 000 15	1599 mm

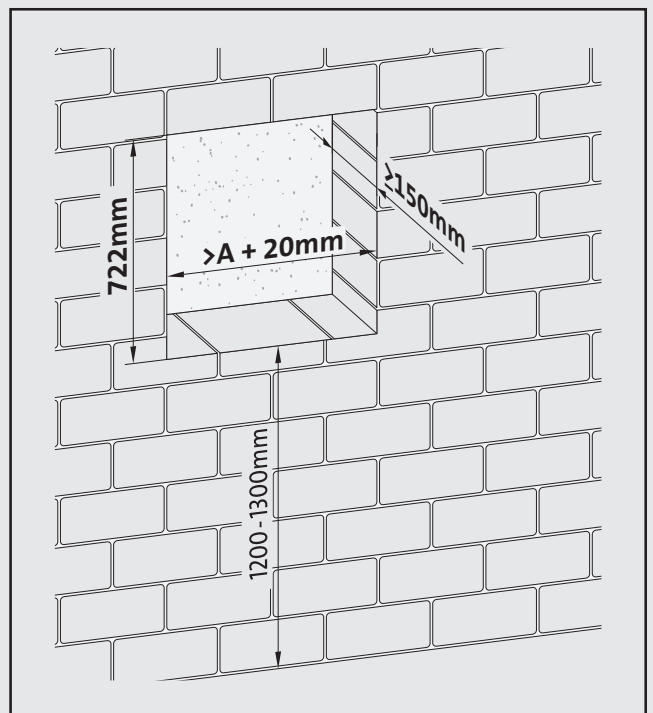
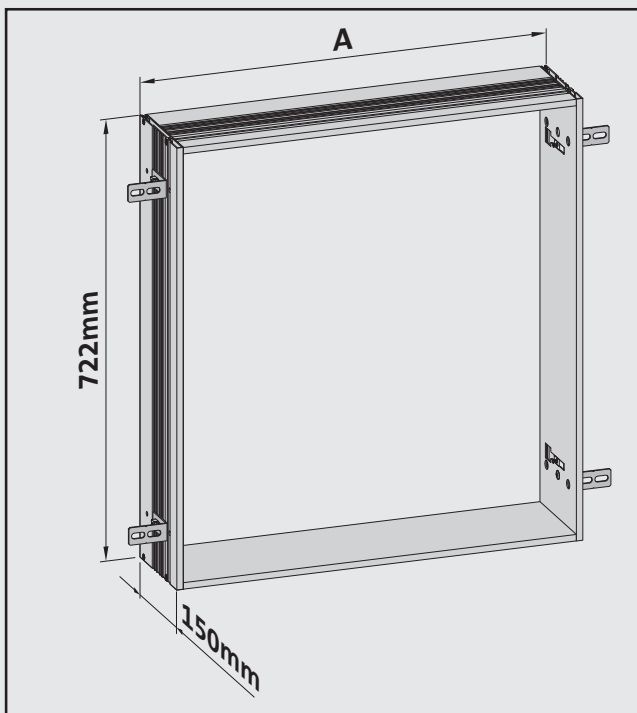



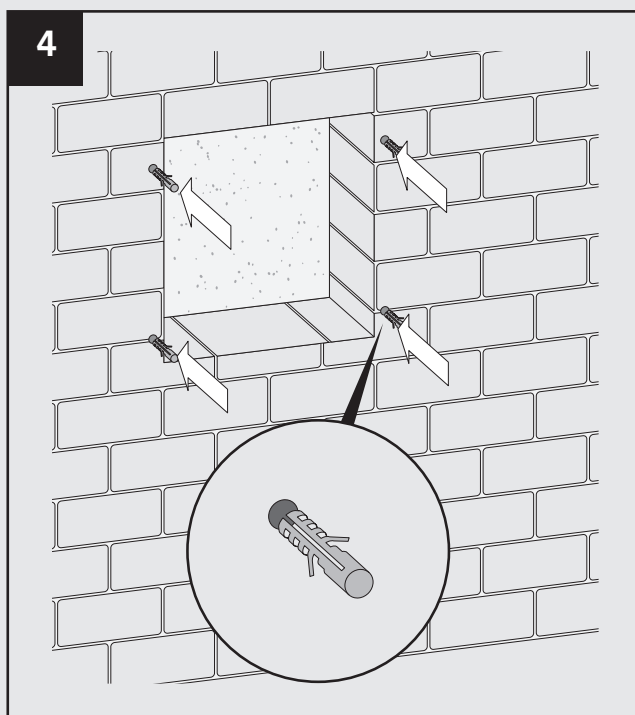
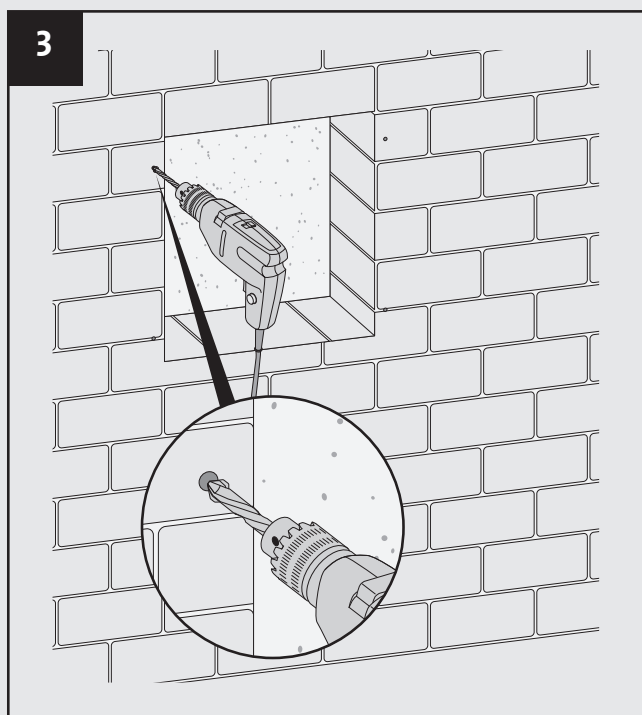
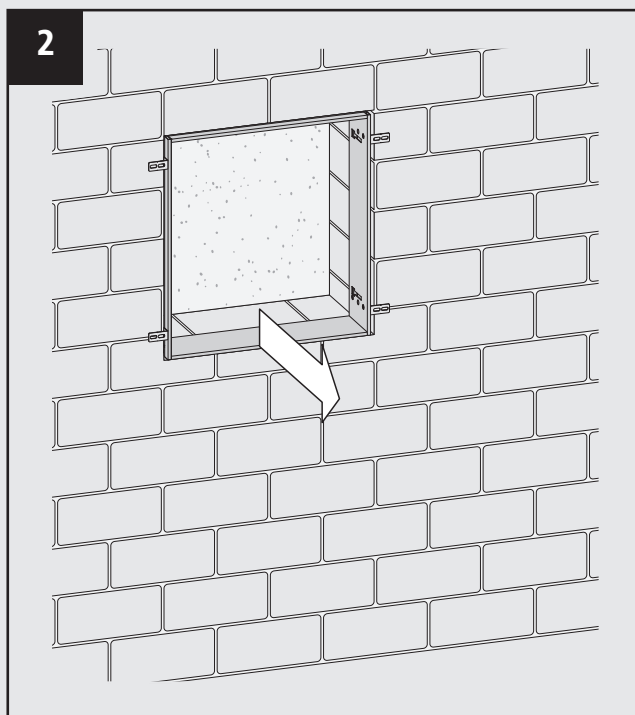
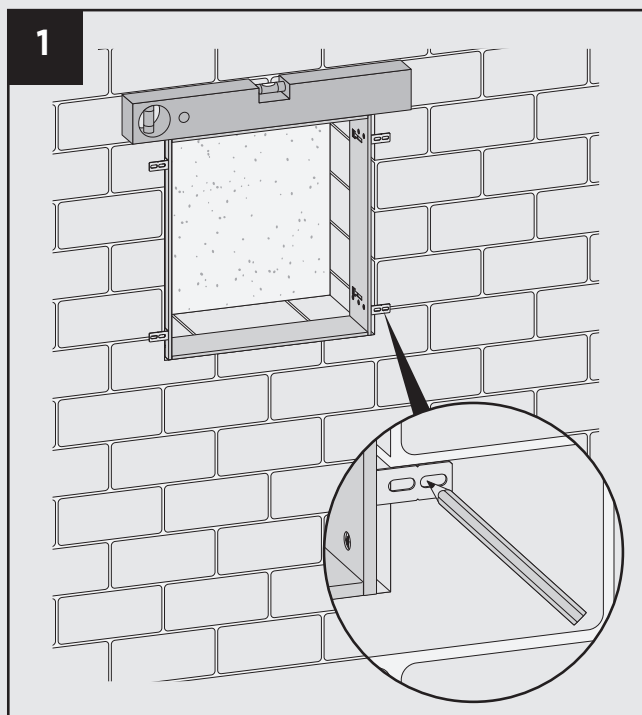

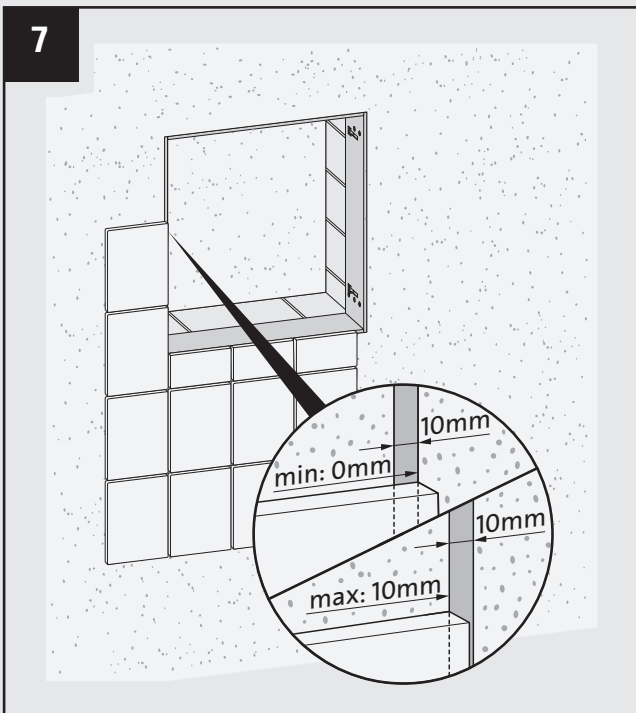
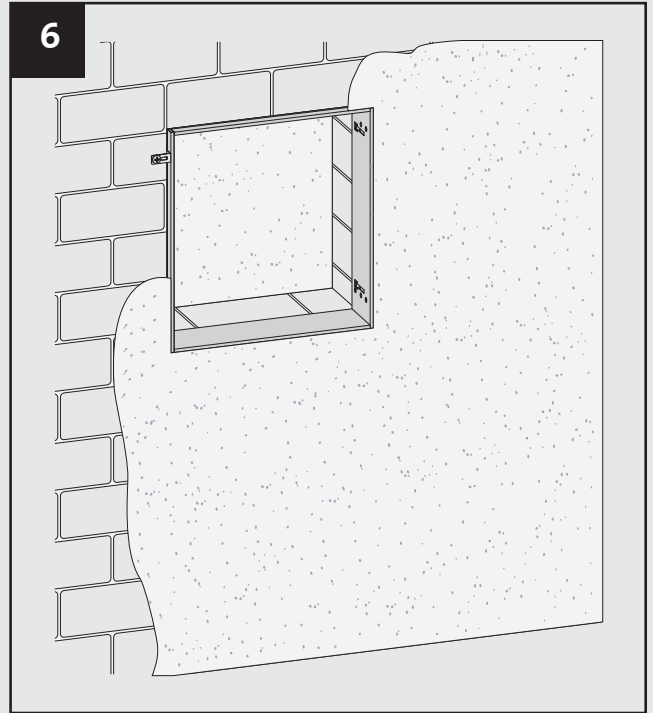
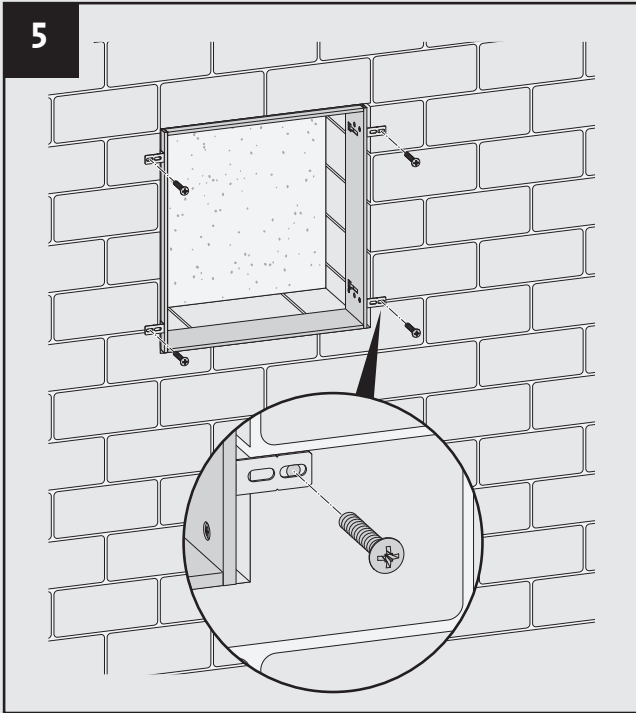



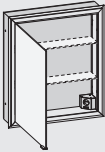

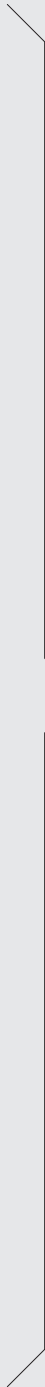
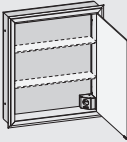

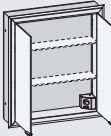

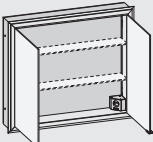

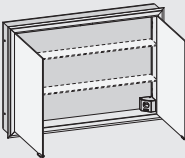

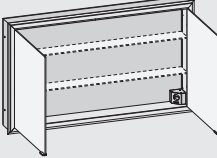
montage einbaurahmen in mauerwerk · installation frame in masonry · montage châssis à encastrer
montage van inbouw-raam in metselwerk

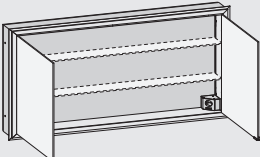

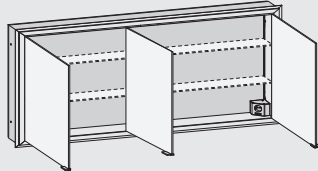







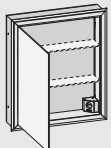

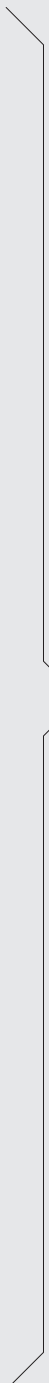
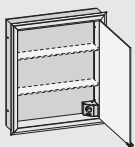

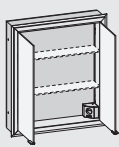

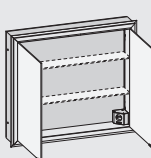

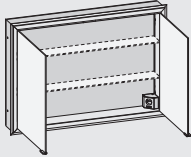

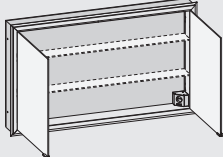

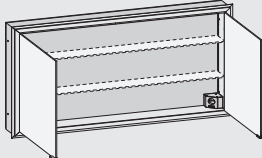
lieferumfang · scope of delivery · quantité livrée · leveromvang
 (ohne Lichtpaket, without light package, sans option lumineux, zonder lichtpakket)

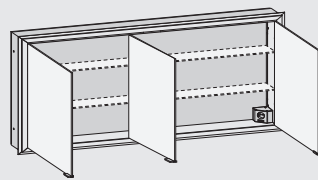
9497 XXX 31 9497 XXX 31 9497 XXX 69 9497 XXX 69		2x 	
9497 XXX 32 9497 XXX 32 9497 XXX 70 9497 XXX 70		2x 	
9497 XXX 33 9497 XXX 33 9497 XXX 71 9497 XXX 71		2x 	
9497 XXX 34 9497 XXX 34 9497 XXX 72 9497 XXX 72		2x 	
9497 XXX 55 9497 XXX 55 9497 XXX 93 9497 XXX 93		2x 	
9497 XXX 56 9497 XXX 56 9497 XXX 94 9497 XXX 94		2x 	
9497 XXX 57 9497 XXX 57 9497 XXX 95 9497 XXX 95		2x 	
9497 XXX 58 9497 XXX 58 9497 XXX 96 9497 XXX 96		2x  2x 	
			1x 

lieferungsumfang · scope of delivery · quantité livrée · leveromvang
 (mit Lichtpaket, with light package, avec option lumineux, met lichtpakket)

9497 XXX 31 9497 XXX 31 9497 XXX 69 9497 XXX 69		2x 	
9497 XXX 32 9497 XXX 32 9497 XXX 70 9497 XXX 70		2x 	
9497 XXX 33 9497 XXX 33 9497 XXX 71 9497 XXX 71		2x 	
9497 XXX 34 9497 XXX 34 9497 XXX 72 9497 XXX 72		2x 	
9497 XXX 55 9497 XXX 55 9497 XXX 93 9497 XXX 93		2x 	
9497 XXX 56 9497 XXX 56 9497 XXX 94 9497 XXX 94		2x 	
9497 XXX 57 9497 XXX 57 9497 XXX 95 9497 XXX 95		2x 	
9497 XXX 58 9497 XXX 58 9497 XXX 96 9497 XXX 96		2x  2x 	
			1x 

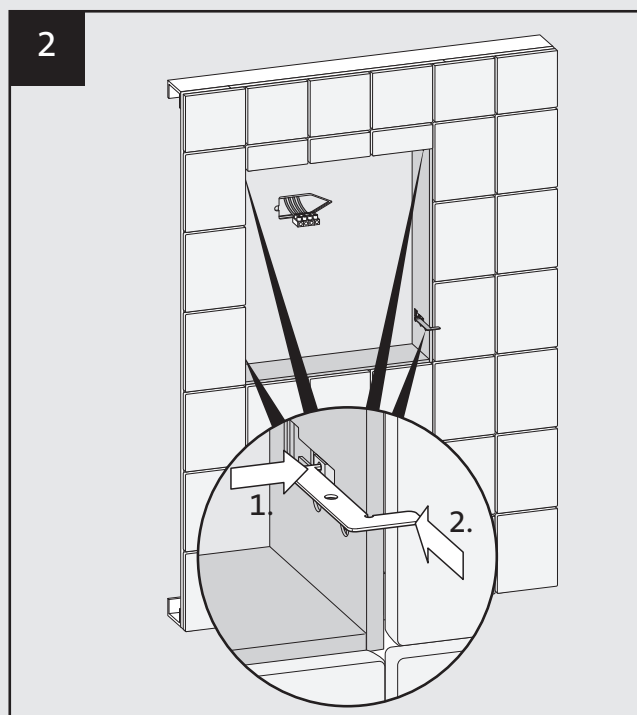
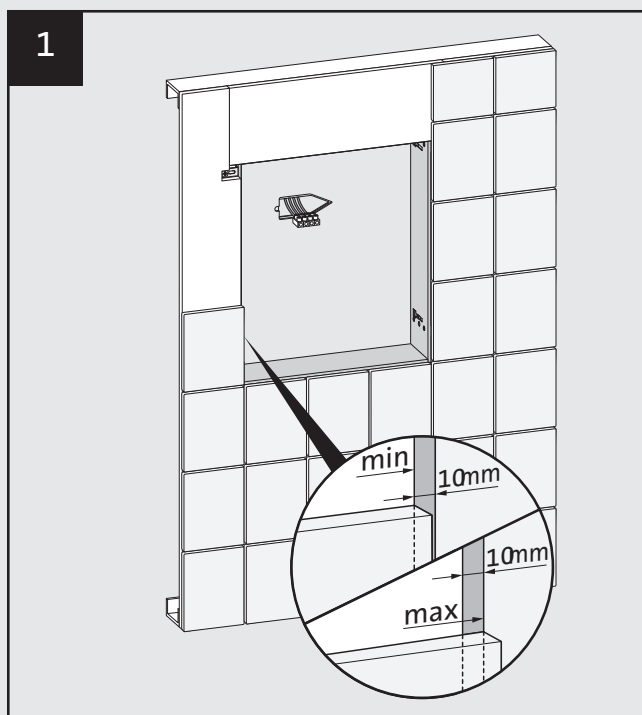
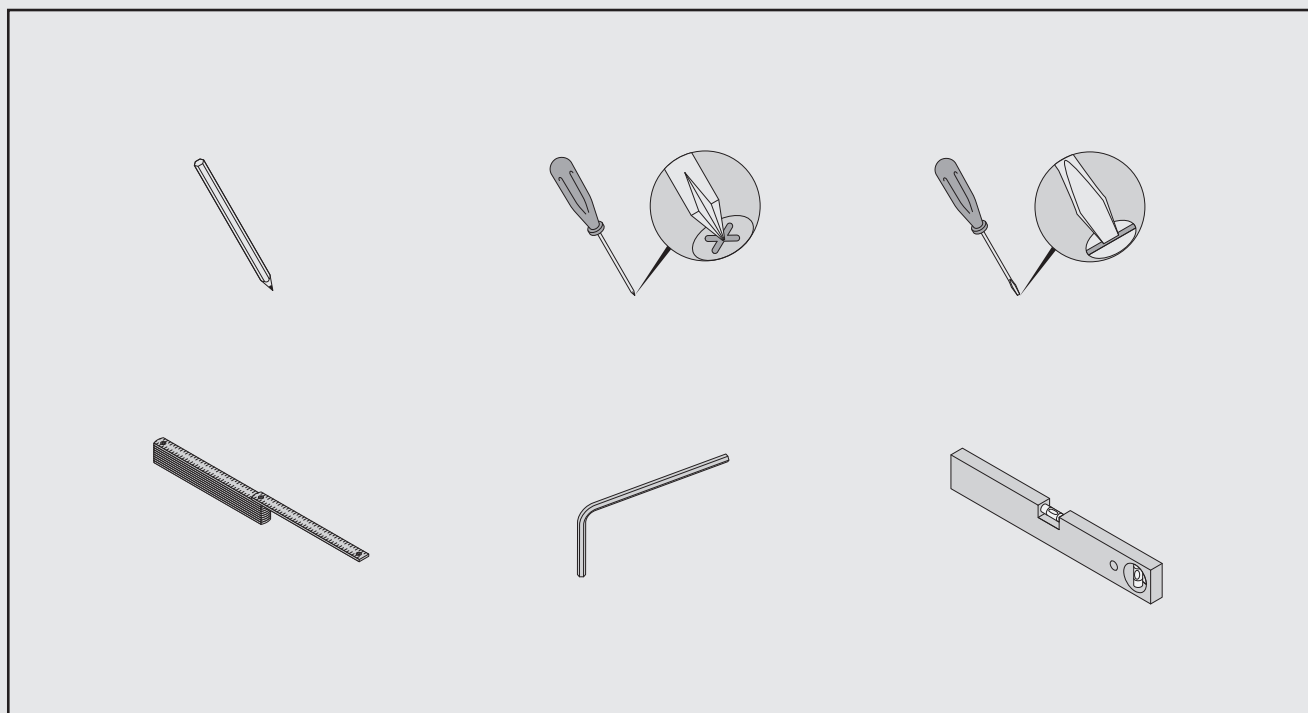

montage einbauversion · installing build in version · montage version encastrable · montage inbouwversie
 montage einlegeböden · mounting the shelves · montage fond encastré · montage glazen schapjes

3

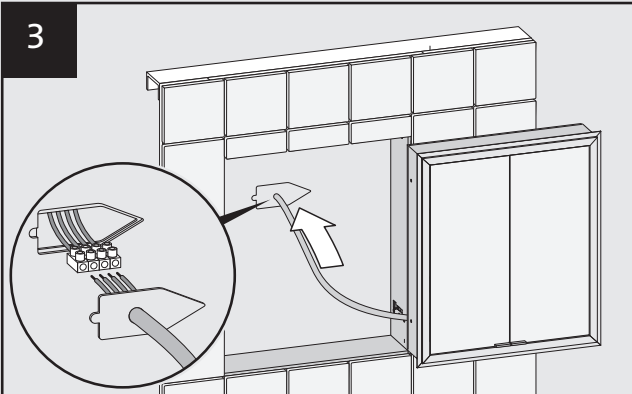

Es sind drei bzw. vier Klemmen erforderlich
 (min. 1,5mm², min. 240V, 16A, EN 60998-2-1)

Three or four terminals are required
 (min. 1,5mm², min. 240V, 16A, EN 60998-2-1)

Trois ou quatre bornes sont nécessaires
 (min. 1,5mm², min. 240V, 16A, EN 60998-2-1)

Hier zijn drie of vier klemmen vereist
 (min. 1,5mm², min. 240V, 16A, EN 60998-2-1)

4

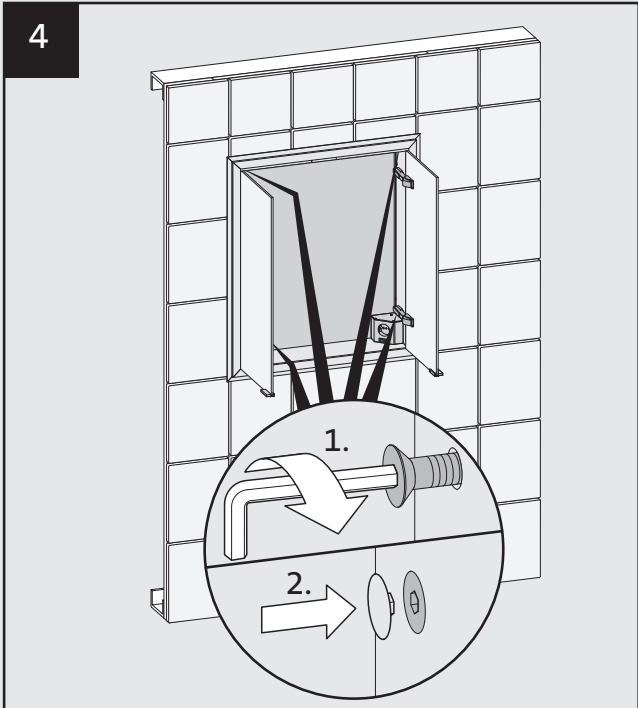

1.

2.

5

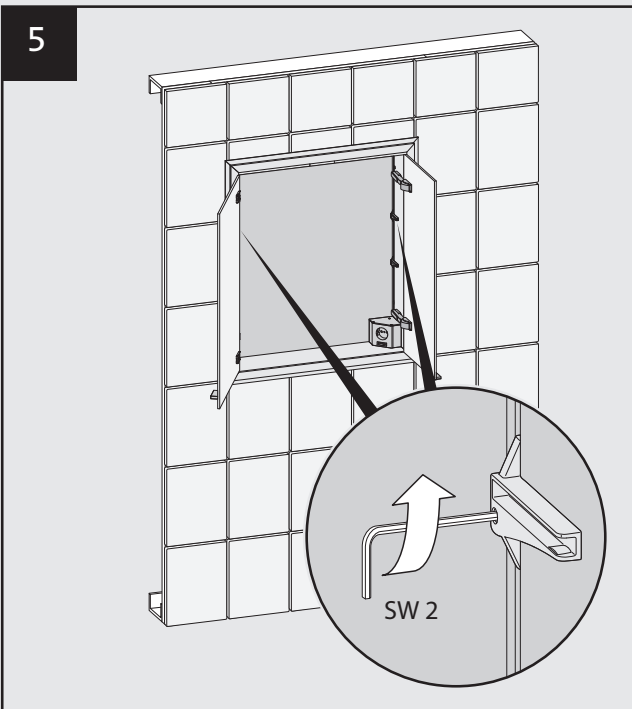

SW 2

6

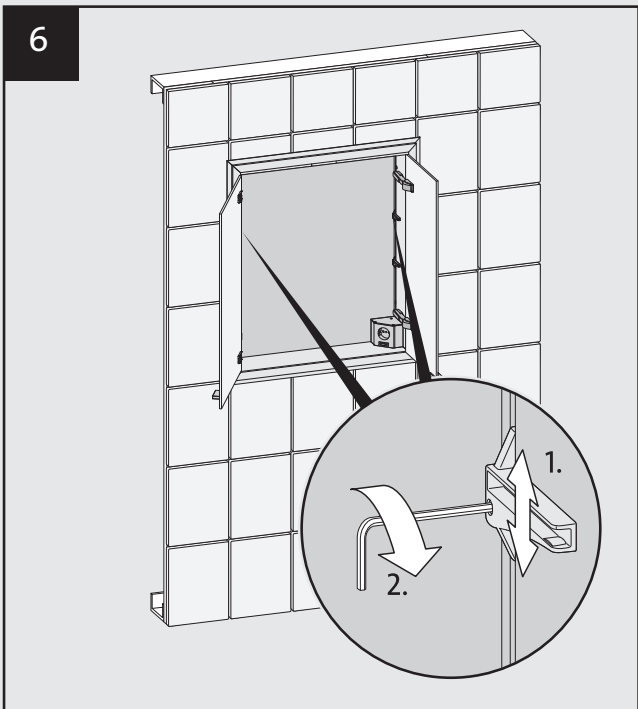

1.

2.

montage einlegeböden · mounting the shelves · montage fond encastré · montage glazen schapjes

bedienung lichtpaket · operation light package · commande des option lumineux · instellen van de lichtpakket

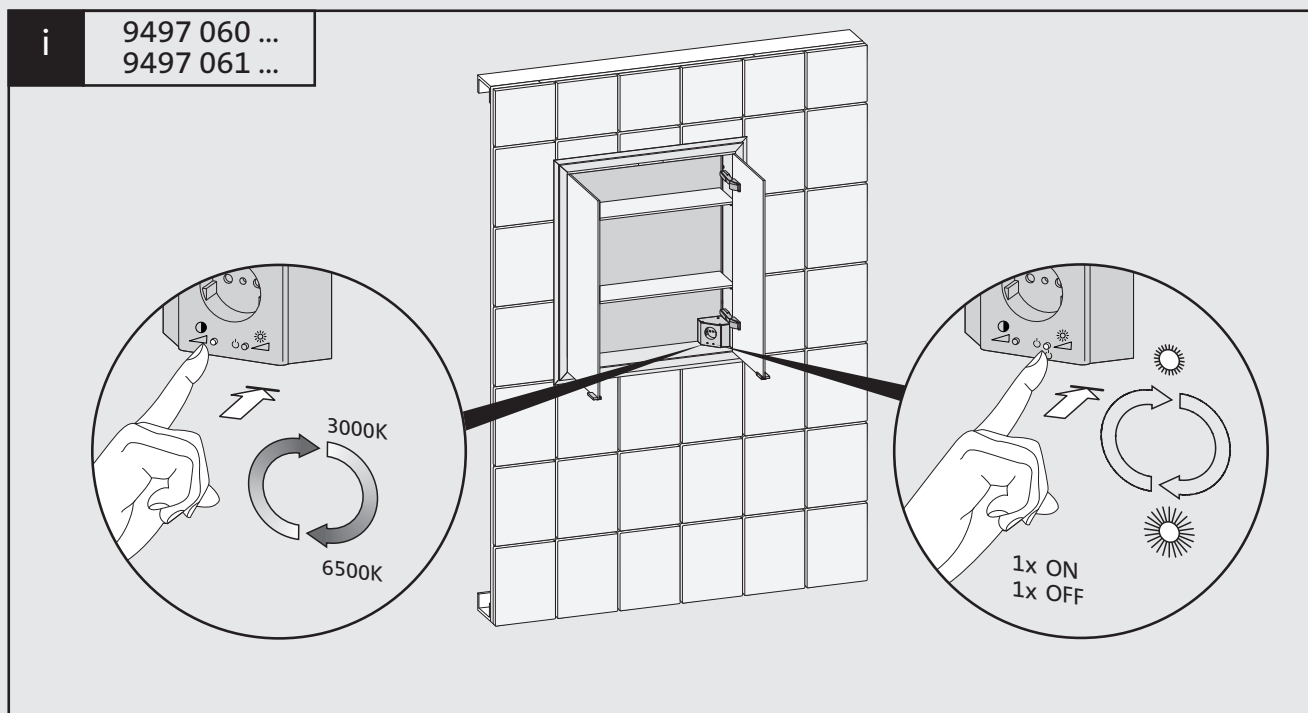
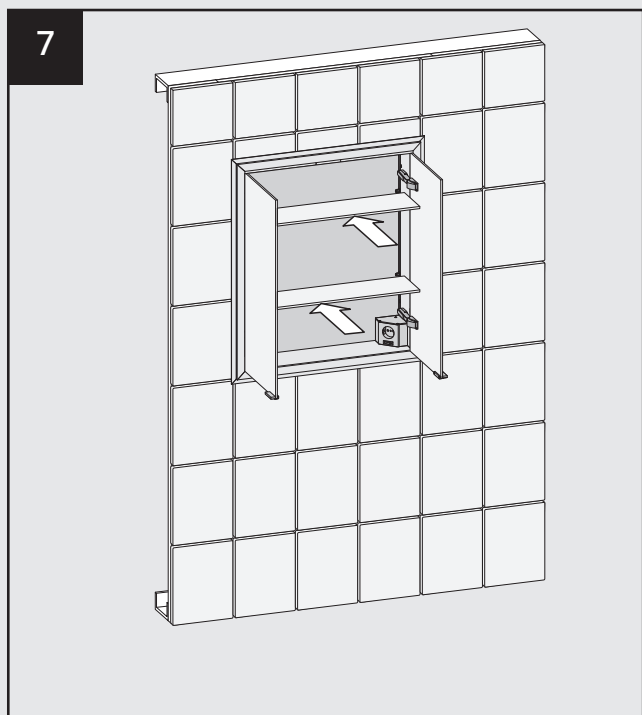

einstellungen scharniere · adjusting hinges · réglage des charnières · instellen van de scharnieren

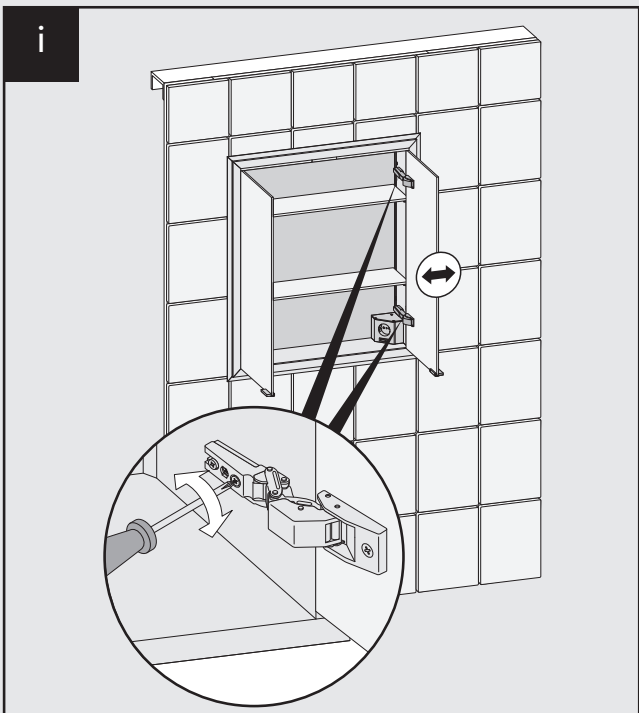
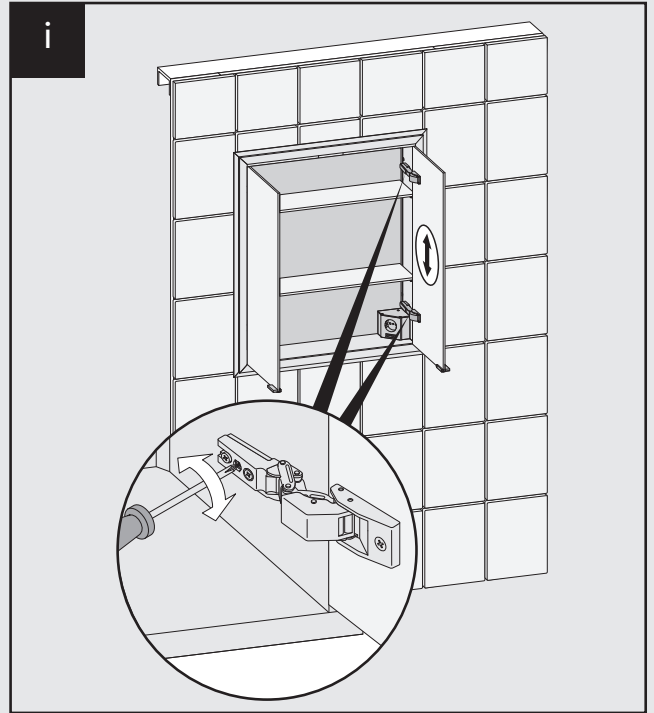
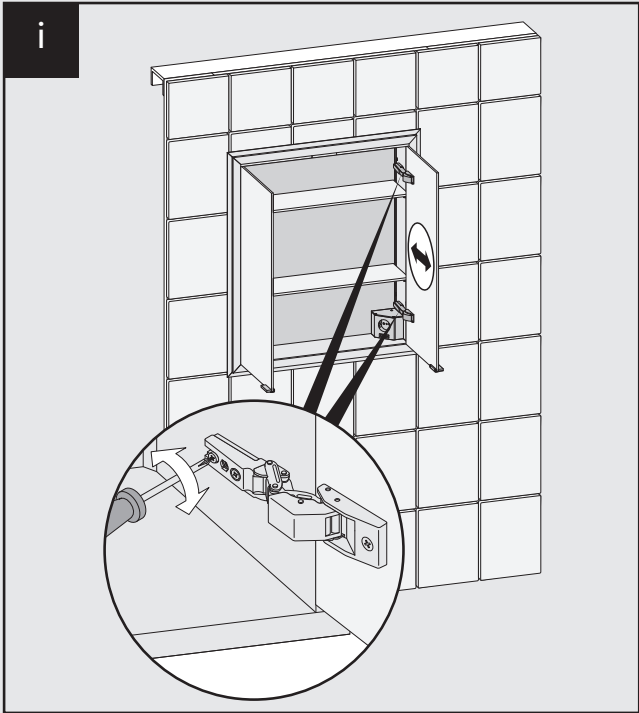

Damit Sie möglichst lange Freude an Ihren hochwertigen EMCO Produkten haben, beachten Sie bitte folgende Pflegehinweise: Reinigen Sie die Module mit einem Tuch oder Lederlappen und klarem, handwarmen Wasser. Bei starken Verschmutzungen können Sie auch ein mildes, hautfreundliches Spülmittel verwenden. **Verwenden Sie keine Reinigungsmittel, die scheuern, Alkohol enthalten oder auf einer Essigsäure aufgebaut sind. Sogenannte Kalkentferner dürfen ebenfalls nicht verwendet werden.** Die **Glasflächen** bitte nur mit einem feuchten Fensterleder reinigen. Die Glaskanten nur trocken abwischen. **Verwenden Sie bitte keine handelsüblichen Glasreinigungsmittel.** Nach der Reinigung ist es wichtig, alle Flächen mit einem weichen, fusselreifen Tuch trocken zu reiben. Bitte heben Sie diese Montage- und Pflegeanleitung gut auf, denn **Schäden, die durch eine unsachgemäße Behandlung entstehen, unterliegen nicht unserer Gewährleistung.**

To ensure the longevity of your EMCO products, we strongly recommend that you follow these care instructions: Clean the modules with a soft textile or leather cloth and clear, lukewarm water. If there is heavy dirt, you may use a mild dishwashing detergent. **Please do not use any cleaning agents that scour, contain alcohol or are based on acetic acids. Furthermore, any agents containing lime-remover should not be used. Glass surfaces** should be cleaned only with a damp chamois. Glass edges should be wiped with a soft, dry cloth. **Please do not use conventional glass cleaners.** After cleaning, rub dry all surfaces with a soft, lint-free cloth. Please keep these installation and care instructions in a safe place and take care to heed these instructions at all times. **Damages that result from inappropriate handling or care are not covered by the guarantee.**

Afin de profiter le plus longtemps possible de vos produits de qualité EMCO, nous vous prions de bien vouloir observer les conseils d'entretien suivants: Nettoyez le module à l'aide d'un tissu ou d'une peau de chamois et d'eau pure tiède. En cas de taches tenaces vous pouvez aussi utiliser un produit nettoyant doux pour les mains. **N'employez pas de produits qui contiennent des substances abrasives, de l'alcool ou du vinaigre. Les produits appelés „détartrants“ conviennent tout aussi peu.** Veuillez essuyer les **surfaces en verre** à l'aide d'une peau de chamois humide; les bords sont à nettoyer avec un tissu sec. **N'utilisez pas les nettoyeurs pour vitres disponibles dans le commerce.** Il est important, après avoir nettoyé, de sécher toutes les taches humides à l'aide d'un linge doux et non pluchant. **Respectez s'il vous plaît scrupuleusement ces conseils de montage et d'entretien, car la garantie n'inclut pas le traitement impropre de nos produits.**

Om u zo lang mogelijk plezier aan uw hoogwaardige EMCO producten te laten beleven, schrijven wij het volgende onderhoudsvoorschrift. Reinig uw module met een vochtige, schone doek. Bij sterke vervuiling adviseren wij een zachte vloeibare zeep te gebruiken (**geen schoonmaakproducten welke schuurmiddel, alcohol of azijnzuur bevatten**). **Zogenaamde kalkverwijderaars mogen eveneens niet toegepast worden.** De **glasdeuren** alstublieft met een vochtige doek reinigen (**in geen geval agressieve glasreinigingsmiddelen gebruiken**). Na de reiniging is het belangrijk alle delen met een schone, droge doek na te drogen. **Wij verzoeken u vriendelijk dit onderhoudsvoorschrift op te volgen want beschadiging welke door slecht onderhoud is ontstaan, valt niet onder de garantie.**

emco Bad GmbH
Postfach 1860
D - 49803 Lingen (Ems)
Tel. +49 (0) 591 91 40-0
Fax +49 (0) 591 91 40-831
bad@emco.de

www.emco.de

Ein Unternehmen der

